



Product Catalog

Model CXAM
AquaStream 3G™
Air-Cooled Liquid Reversible Heat Pumps





Introduction

Design and manufacturing excellence makes Trane a leader in the air-cooled chiller marketplace. This tradition of using excellence to meet market demands is illustrated with the new Trane AquaStream 3G the 55-450 kW air-cooled cooling unit. The introduction of this next-generation chiller is an exciting step forward in energy-efficiency, sound, reliability, ease of serviceability, control precision, application versatility, and operational cost-effectiveness. The new chiller is designed to deliver proven AquaStream 3G performance based on the redesign of a European model that has been a market leader, plus all the benefits of new heat transfer and fan designs, as well as, low-speed, direct-drive scroll compressors.

Important Design Advances and New Features

- Higher full-load and part-load energy efficiency that reduce operating costs.
- Significantly lower noise levels than other scroll compressor chillers.
- HFC-410A optimized design.
- Factory-installed evaporator pump and buffer tank available to make installation easier.
- Flow switch and water strainer are factory installed in the optimum locations for seamless operation and reduced chiller installation and maintenance time.
- Trane CH530™ with Adaptive Controls™ have improved fan algorithms for more reliable operation at extreme conditions.
- Single chiller time of day scheduling communication for easier control of small jobs.
- Easily integrated with existing BAS via BACnet™, Modbus™, or LonTalk™ communication interface.
- All major service components are close to the unit edge for safe and easy maintenance.
- The chiller is designed for easy serviceability with input from our extended experience in design, testing and field operation.

Table of Contents

Features and Benefits	4
Application Considerations	7
Model Number Descriptions	16
General Data	18
Controls	54
Dimensions	60
Mechanical Specifications	67
Options	70
Hydraulic Data	75
Operating Map	79
Unit Schematics	81

Features and Benefits

Reliability

- Years of laboratory testing including running the chiller at extreme operating conditions have resulted in optimized compressor and chiller systems reliability by confirming a robust design and verifying quality each step of the way.
- Direct-drive, low-speed scroll compressors with fewer moving parts provide maximum efficiency, high reliability, and low maintenance requirements. Suction gas-cooled motor stays at a uniformly low temperature for long motor life.
- The third generation microprocessor control system provides improved control capabilities with Adaptive Control™ to keep the unit operating even in adverse conditions. Advanced microelectronics protect both the compressor and the motor from typical electrical fault conditions like thermal overload and phase rotation.
- Flow switch is factory-installed at the optimum location in the piping for reduced chiller installation cost and superior flow sensing, reducing the potential for nuisance trips.
- Exceptionally rigid condenser coil structure is designed with finished element analysis.
- Innovative condenser pressure integrated fan control algorithms provide more reliable operation at extreme temperature conditions.
- Systematic factory run test prior to shipment.

Efficient, economical and environmentally friendly operation

- Industry leading full- and part-load efficiency in both cooling and heating mode, providing economical operation and reduced CO2 emissions.
- Electronic expansion valve and high speed suction temperature sensor enables tight chilled water temperature control and low superheat, resulting in more efficient full-load and part-load operation than previously available.
- Optional water pumps inverter to adjust pump speed/waterflow rate and achieve all year round savings.
- 410a refrigerant: a chlorine-free refrigerant with no negative impact on the ozone layer.
- Refrigerant leakage reduced thanks to high rigidity frame, brazed refrigerant connections, extensive pressure and leakage testing all along the production process

Application Versatility

- All year round operation: cooling capability from -18°C ambient up to 52°C with leaving water down to -12°C. Heating capability down to -10°C ambient and leaving water temperature up to 55°C.
- Industrial/low temperature process cooling - Excellent operating temperature range and precise control capabilities enable tight control.
- Ice/thermal storage - Utilities and owners benefit from reduced cooling energy cost. The AquaStream 3G chiller's dual setpoint control and industry leading ice energy storage efficiency assures reliable operation and superior system efficiency.
- The factory-installed and tested pump package available with many options to meet a variety of customer needs.

Simple, Economical Installation

- There is a variety of sound options to help meet many different job site requirements: compact, super quiet and comprehensive acoustic package.
- System integration available with LonTalk, or ModBus, or BACnet through a single twisted-pair wire for a less expensive translation to an existing building automation system.
- Powder-coated paint provides superior durability, corrosion protection, and is less likely to be damaged while rigging/lifting/installing the chiller.
- Factory commissioned unit-mounted starter reduces overall job cost and improves system reliability by eliminating job site design, installation and labor coordination requirements.

Precision Control

- Microprocessor-based Trane CH530 controls monitor and maintain optimal operation of the chiller and its associated sensors, actuators, relays, and switches, all of which are factory-installed, powered up and tested prior to shipping.
- Adaptive Control maintains chiller operation under adverse conditions, when many other chillers might simply shut down. Operating conditions that are compensated for include high condensing pressure and low suction pressure.



Features and Benefits

- AquaStream 3G advanced microprocessor controls enable variable primary flow applications providing chilled water temperature control accuracy of $\pm 2^{\circ}\text{F}$ (1.1°C) for flow changes up to 10 percent per minute, plus handling of flow changes up to 30 percent per minute with continuous operation.
- Easy-to-use operator interface displays all operating and safety messages, with complete diagnostics information, on a highly readable panel with a scrolling touch-screen display. Status and diagnostic messages are in plain language - no codes to interpret - and are available in 20 languages.

Improved Serviceability

- All major serviceable components are close to the edge. Service shutoff valves and water strainer are conveniently located to enable easy service.
- Water piping connections are factory piped to the edge of the unit to make installation safer and faster.
- Electronic expansion valve designed so controls can be removed and serviced without refrigerant handling.
- The optional pump package is designed to be serviced in place. The unit structure includes a rigging point for pump servicing, making inspection, cleaning and pump seal changes easier.
- High pressure transducer and temperature sensors mountings enable troubleshooting and replacement without removing refrigerant charge, greatly improving serviceability over the life of the unit.
- Dead front panel construction provides for enhanced service technician safety.
- Y shaped water strainer to allow easy cleaning with minimum disassembly

Application Considerations

Certain application constraints should be considered when sizing, selecting and installing Trane AquaStream 3G chillers and heat pumps. Unit and system reliability is often dependent upon proper and complete compliance with these considerations. Where the application varies from the guidelines presented, it should be reviewed with your local Trane sales engineer.

Note: *The terms water and solution are used interchangeably in the following paragraphs.*

Unit Sizing

Intentionally over-sizing a unit to assure adequate capacity is not recommended. Erratic system operation and excessive compressor cycling are often a direct result of an oversized chiller. In addition, an oversized unit is usually more expensive to purchase, install, and operate. If over sizing is desired consider using two smaller units.

Water Treatment

The use of untreated or improperly treated water in chillers may result in scaling, erosion, corrosion, and algae or slime buildup. This will adversely affect heat transfer between the water and system components. Proper water treatment must be determined locally and depends on the type of system and local water characteristics.

Neither salt nor brackish water is recommend for use in Trane air-cooled AquaStream 3G chillers. Use of either will lead to a shortened life. Trane encourages the employment of a qualified water treatment specialist, familiar with local water conditions, to assist in the establishment of a proper water treatment program.

Foreign matter in the chilled water system can also increase pressure drop and, consequently, reduce water flow. For this reason it is important to thoroughly flush all water piping to the unit before making the final piping connections to the unit.

Effect of Altitude on Capacity

At elevations substantially above sea level, the decreased air density will decrease condenser capacity and, therefore, unit capacity and efficiency.

Ambient Limitations

Trane AquaStream 3G chillers are designed for year-round operation over a range of ambient temperatures. The unit will operate in ambient temperatures of 46°C. Selecting the low ambient option will allow the unit to operate with ambient temperature as low as -18°C and high ambient option will increase the operational capability of the unit to operate in ambient temperatures up to 52°C. The heat pump will operate in cooling mode up to 46°C and down to -10°C. with the low ambient option. In heating mode the heat pump will operate down to -10°C as standard.

The minimum ambient temperatures are based on still conditions (winds not exceeding 8 km/h). Greater wind velocities will result in a drop in head pressure, therefore increasing the minimum starting and operating ambient temperature. The Adaptive Control™ microprocessor will attempt to keep the chiller on-line when high or low ambient conditions exist, making every effort to avoid nuisance trip-outs and provide the maximum allowable tonnage.

Water Flow Limits

The minimum water flow rates are given in the General Data section of this catalog. Evaporator flow rates below the tabulated values will result in laminar flow causing freeze-up problems, scaling, stratification and poor control. The maximum evaporator water flow rate is also given. Flow rates exceeding those listed may result in very high pressure drop across the evaporator.

Flow Rates Out of Range

Many process cooling jobs require flow rates that cannot be met with the minimum and maximum published values within the AquaStream 3G evaporator. A simple piping change can alleviate this problem. For example: a plastic injection molding process requires 5.0 l/s of 10°C water and returns that water at 15.6°C. The selected chiller can operate at these temperatures, but has a minimum flow rate of 6.6 l/s. The system layout in Figure 1 can satisfy the process.

Figure 1. Flow Rate Out of Range Systems Solution

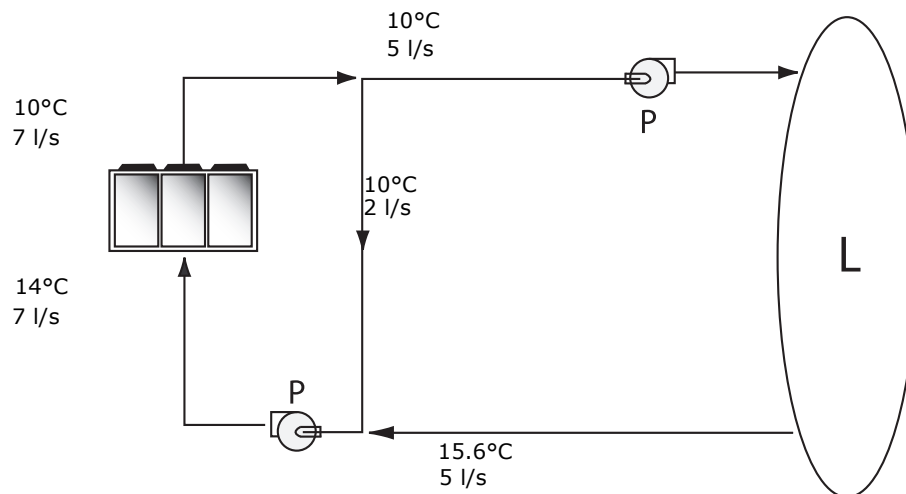

Flow Proving

Trane provides a factory-installed water flow switch monitored by CH530 which protects the chiller from operating in loss of flow conditions.

Variable Flow in the Evaporator

An attractive chilled water system option may be a Variable Primary Flow (VPF) system. VPF systems present building owners with several cost-saving benefits when compared with Primary/Secondary chilled water systems. The most obvious cost savings results from eliminating the constant volume chiller pump(s), which in turn eliminates the related expenses of the associated piping connections (material, labor), and electrical service and switch gear. In addition to the installed cost advantage building owners often cite pump related energy savings as the reasons that prompted them to select a VPF system.

The AquaStream 3G has the capability to handle variable evaporator flow without losing leaving water temperature control. The microprocessor and capacity control algorithms are designed to take a 10 percent change in water flow rate per minute while maintaining a $\pm 1.1^{\circ}\text{C}$ leaving water temperature control accuracy. The chiller tolerates up to 30 percent per minute water flow variation as long as the flow is equal or above the minimum flow rate requirement.

With the help of a software analysis tool such as System Analyzer™, DOE-2 or TRACE™, you can determine whether the anticipated energy savings justify the use of variable primary flow in a particular application. Existing constant flow chilled water systems may be relatively easily converted to VPF and benefit greatly from the inherent efficiency advantages.

Water Temperature - cooling mode

Leaving Water Temperature Limits

Trane AquaStream 3G chillers have three distinct leaving water categories:

- standard, with a leaving solution range of 5.5 to 18°C
- low temperature process cooling, with leaving solution range of -10 to 18°C
- ice-making, with leaving solution range of -7 to 18°C

Since leaving solution temperature below 5.5°C results in suction temperature at or below the freezing point of water, a glycol solution is required for all low temperature and ice-making machines. Ice making control includes dual setpoint controls and safeties for ice making and standard cooling capabilities. Consult your local Trane sales engineer for applications or selections involving low temperature or ice making machines.

Leaving Water Temperature Out of Range

Similar to the flow rate limitations above, many process cooling jobs require temperature ranges that are outside the allowable minimum and maximum operating values for the chiller. Figure 2 below shows a simple example of a mixed water piping arrangement change that can permit reliable chiller operation while meeting such cooling conditions. For example, a laboratory load requires 5 l/s of water entering the process at 30°C and returning at 35°C. The chiller's maximum leaving chilled water temperature of 15.6°C. In the example shown, both the chiller and process flow rates are equal, however, this is not necessary. For example, if the chiller had a higher flow rate, there would simply be more water bypassing and mixing with warm water returning to the chiller.

Figure 2. Temperature Out of Range System Solution

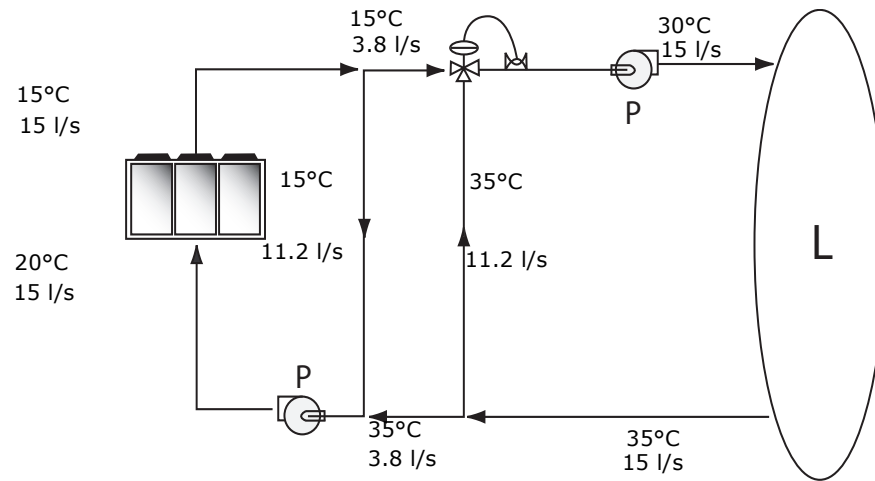

Supply Water Temperature Drop

Full load chilled water temperature drops from 3.3 to 10°C may be used as long as minimum and maximum water temperature and minimum and maximum flow rates are not violated. Temperature drops outside this range at full load conditions are beyond the optimum range for control and may adversely affect the microcomputer's ability to maintain an acceptable supply water temperature range. Furthermore, full load temperature drops of less than 3.3°C may result in inadequate refrigerant superheat which is critical to long term efficient and reliable operation. Sufficient superheat is always a primary concern in any refrigerant system and is especially important in a packaged chiller where the evaporator is closely coupled to the compressor.

Parameters which influence the water temperature stability:

- Ambient temperature and water temperature (modify cooling capacity)
- Number of capacity steps
- Minimum time between starts of a compressor
- Control dead band
- Water loop volume
- Load fluctuations
- Fluid type or percentage of glycol

Typical Water Piping

All building water piping must be flushed prior to making final connections to the chiller. To reduce heat loss and prevent condensation, insulation should be applied. Expansion tanks are also usually required so that chilled water volume changes can be accommodated.

Avoidance of Short Water Loops

Adequate chilled water system water volume is an important system design parameter because it provides for stable water temperature control and helps limit unacceptable short cycling of compressors.

The AquaStream 3G heat pump and chiller's temperature control sensor is located in the supply (outlet) water connection or pipe. This location allows the building to act as a buffer to slow the rate of change of the system water temperature. If there is not a sufficient volume of water in the system to provide an adequate buffer, temperature control can suffer, resulting in erratic system operation and excessive compressor cycling.

Typically, a two-minute water loop circulation time is sufficient to prevent short water loop issues. Therefore, as a guideline, ensure the volume of water in the water loop equals or exceeds two times the evaporator flow rate. For systems with a rapidly changing load profile the amount of volume should be increased.

If the installed system volume does not meet the above recommendations, the following items should be given careful consideration to increase the volume of water in the system and, therefore, reduce the rate of change of the return water temperature.

- A volume buffer tank located in the return water piping.
- Larger system supply and return header piping (which also reduces system pressure drop and pump energy use).



Application Considerations

An optional factory-installed buffer tank is designed to meet the minimum two minute loop time without additional job site piping. The buffer tank can also be used on jobs that already meet or exceed the minimum loop time to further reduce the potential for compressor cycling, increasing the compressor life span, and reducing system temperature fluctuations.

Minimum water volume for a process application

If a chiller is attached to an on/off load such as a process load, it may be difficult for the controller to respond quickly enough to the very rapid change in return solution temperature if the system has only the minimum water volume recommended. Such systems may cause chiller low temperature safety trips or in the extreme case evaporator freezing. In this case, it may be necessary to add or increase the size of the mixing tank in the return line or consider the optional factory-installed buffer tank with the chiller.

Multiple Unit Operation

Whenever two or more units are used on one water loop, Trane recommends that their operation be coordinated with a higher level system controller for best system efficiency and reliability. The Trane Tracer system has advanced plant control capabilities designed to provide such operation.

Ice Storage Operation

An ice storage system uses the chiller to make ice at night when utilities generate electricity more efficiently and charge less for electricity with lower demand and energy charges. The stored ice reduces or even replaces mechanical cooling during the day when utility rates are at their highest. This reduced need for cooling results in significant utility cost savings and source energy savings.

Another advantage of an ice storage system is its ability to eliminate chiller over sizing. A "rightsized" chiller plant with ice storage operates more efficiently with smaller support equipment while lowering the connected load and reducing operating costs. Best of all this system still provides a capacity safety factor and redundancy by building it into the ice storage capacity for practically no cost compared to over sized systems.

The Trane air-cooled chiller is uniquely suited to low temperature applications like ice storage because of the ambient relief experienced at night. Chiller ice making efficiencies are typically similar to or even better than standard cooling daytime efficiencies as a result of night-time dry-bulb ambient relief.

Standard smart control strategies for ice storage systems are another advantage of the AquaStream 3G chiller. The dual mode control functionality are integrated right into the chiller. Trane Tracer building management systems can measure demand and receive pricing signals from the utility and decide when to use the stored cooling and when to use the chiller.

Unit Placement

Setting The Unit

A base or foundation is not required if the selected unit location is level and strong enough to support the unit's operating weight (see "Weights" section of this catalog).

For a detailed discussion of base and foundation construction, refer to the sound engineering bulletin or the unit IOM. Manuals are available through the local Trane office.

HVAC equipment must be located to minimize sound and vibration transmission to the occupied spaces of the building structure it serves. If the equipment must be located in close proximity to a building, it should be placed next to an unoccupied space such as a storage room, mechanical room, etc. It is not recommended to locate the equipment near occupied, sound sensitive areas of the building or near windows. Locating the equipment away from structures will also prevent sound reflection, which can increase sound levels at property lines or other sensitive points.

Isolation and Sound Emission

Structurally transmitted sound can be reduced by elastomeric vibration eliminators. Elastomeric isolators are generally effective in reducing vibratory noise generated by compressors, and therefore, are recommended for sound sensitive installations. An acoustical engineer should always be consulted on critical applications.

Figure 3. Installation Example

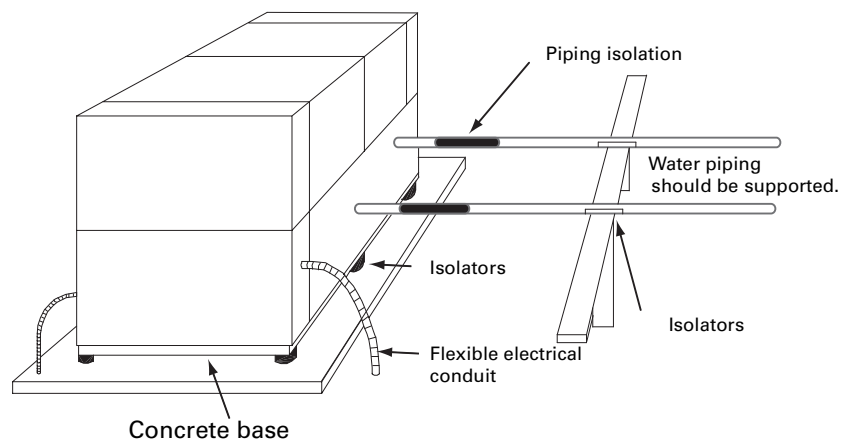



Application Considerations

For maximum isolation effect, water lines and electrical conduit should also be isolated. Wall sleeves and rubber isolated piping hangers can be used to reduce the sound transmitted through water piping. To reduce the sound transmitted through electrical conduit, use flexible electrical conduit.

Local codes on sound emissions should always be considered. Since the environment in which a sound source is located affects sound pressure, unit placement must be carefully evaluated. Sound power levels for chillers are available on request.

Servicing

Adequate clearance for evaporator and compressor servicing should be provided. Recommended minimum space envelopes for servicing are located in the dimensional data section and can serve as a guideline for providing adequate clearance. The minimum space envelopes also allow for control panel door swing and routine maintenance requirements. Local code requirements may take precedence.

Unit Location

General

Unobstructed flow of condenser air is essential to maintain unit capacity and operating efficiency. When determining unit placement, careful consideration must be given to assure a sufficient flow of air across the condenser heat transfer surface. Two detrimental conditions are possible and must be avoided: warm air recirculation and coil starvation. Air recirculation occurs when discharge air from the condenser fans is recycled back to the condenser coil inlet. Coil starvation occurs when free airflow to the condenser is restricted.

Condenser coils and fan discharge must be kept free of snow or other obstructions to permit adequate airflow for satisfactory unit operation. Debris, trash, supplies, etc., should not be allowed to accumulate in the vicinity of the air-cooled chiller. Supply air movement may draw debris into the condenser coil, blocking spaces between coil fins and causing coil starvation.

Both warm air recirculation and coil starvation cause reductions in unit efficiency and capacity because of the higher head pressures associated with them. The air-cooled AquaStream 3G heat pump offers an advantage over competitive equipment in these situations. Operation is minimally affected in many restricted air flow situations due to its advanced Adaptive Control™ microprocessor which has the ability to understand the operating environment of the unit and adapt to it by first optimizing its performance and then staying on line through abnormal conditions. For example, high ambient temperatures combined with a restricted air flow situation will generally not cause the unit to shut down. Other chillers would typically shut down on a high pressure nuisance cut-out in these conditions.

Cross winds, those perpendicular to the condenser, tend to aid efficient operation in warmer ambient conditions. However, they tend to be detrimental to operation in lower ambients due to the accompanying loss of adequate head pressure. Special consideration should be given to low ambient units. As a result, it is advisable to protect air-cooled chillers and heat pumps from continuous direct winds exceeding 4.5 m/s in low ambient conditions.

The recommended lateral clearances are depicted in the close spacing engineering bulletin available from your local office.

Provide Sufficient Unit-to-Unit Clearance

Units should be separated from each other by sufficient distance to prevent warm air recirculation or coil starvation. Doubling the recommended single unit air-cooled unit clearances will generally prove to be adequate.

Walled Enclosure Installations

When the unit is placed in an enclosure or small depression, the top of the surrounding walls should be no higher than the top of the fans. The heat pump should be completely open above the fan deck. There should be no roof or structure covering the top of the chiller. Ducting individual fans is not recommended.

Model Number Descriptions

Digit 1-4 – Chiller Model

CXAM= Air-Cooled Scroll Packaged Chiller

Digit 5-7 – Unit Nominal Tonnage

020 = 20 Tons
023 = 23 Tons
026 = 26 Tons
030 = 30 Tons
035 = 35 Tons
039 = 39 Tons
040 = 40 Tons
045 = 45 Tons
046 = 46 Tons
050 = 50 Tons
052 = 52 Tons
060 = 60 Tons
070 = 70 Tons
080 = 80 Tons
090 = 90 Tons
100 = 100 Tons
110 = 110 Tons
120 = 120 Tons
140 = 140 Tons
150 = 150 Tons
160 = 160 Tons
170 = 170 Tons

Digit 8 – Unit Voltage

E = 400 Volt 50 Hz 3 Phase

Digit 9 – Manufacturing Plant

1 = Epinal, France

Digit 10-11 – Design Sequence

A-Z = Factory/ABU Assigned

Digit 12 – Unit Type

1 = Standard Efficiency/ Performance
2 = High Efficiency/ Performance

Digit 13 – Agency Listing

B = CE Certification (EUR)

Digit 14 – Pressure Vessel Code

4 = Europe Standard

Digit 15 – Unit Application

E = Standard Ambient heat pump cooling mode (7-46 °C)
F = Low ambient heat pump cooling mode (-10 to 46 °C)

Digit 16 – Refrigerant Isolation Valves

1 = No Isolation Valves

Digit 17

A

Digit 18 – Freeze Protection (Factory-Installed Only)

X = Without Freeze Protection
2 = With Freeze Protection (CH530 Control)

Digit 19 – Insulation

A = Factory Insulation - All Cold Parts

Digit 20 – Factory Charge

1 = Full Factory Refrigerant Charge (HFC-410A)

Digit 21 – Evaporator Application

A = Standard Cooling (5.5 to 18°C)
B = Low Temperature Processing (lower than 5.5°C)
C = Ice-Making - hardwired interface (-7 to 18°C)

Digit 22 – Water Connection (Evap)

1 = Grooved Pipe Connection
2 = Grooved Pipe with Flange Adapter

Digit 23 – Condenser Fin Material

E = Non-Lanced Aluminum Fins w/ Pre-Coat (Black Epoxy)
F = Non-Lanced Aluminum Fins w/ Pre-Coat (Blue Fin)

Digit 24 – Condenser Heat Recovery

X = No Heat Recovery
2 = Partial Heat Recovery w/o Fan Control

Digit 25

X

Digit 26 – Starter Type

A = Across the Line Starter/ Direct on Line
B = Solid State Soft Starter
C = Across the Line Starter/ Power Factor Correction

Digit 27 – Incoming Power Line Connection

1 = Single Point Power Connection

Digit 28 – Power Line Connection Type

B = Disconnect Switch

Digit 29 – Enclosure Type

2 = IP54 Protection

Digit 30 – Unit Operator Interface

A = Dyna-View/English
B = Dyna-View/Spanish-Spain
D = Dyna-View/French
E = Dyna-View/German
F = Dyna-View/Dutch
G = Dyna-View/Italian
J = Dyna-View/Portuguese-Portugal
R = Dyna-View/Russian
T = Dyna-View/Polish
U = Dyna-View/Czech
V = Dyna-View/Hungarian
W = Dyna-View/Greek
Y = Dyna-View/Romanian
Z = Dyna-View/Swedish

Digit 31 – Remote Interface (digital comm)

- X = No Remote Digital Communication
- 1 = LonTalk LCI-C Interface with Modbus Interface
- 2 = LonTalk/Tracer Summit Interface
- 3 = Time of Day Scheduling
- 4 = BACNet Interface

Digit 32 – Ext. Chilled/Hot Water and Curr. Demand Limit Setpoint

- X = No Ext. Chilled Water Setpoint
- A = Ext Chilled Water and Demand Limit Setpoint - 4-20mA
- B = Ext Chilled Water and Demand Limit Setpoint - 2-10Vdc
- C = Auxiliary setpoint

Digit 33 – % Capacity

- X = Without % Capacity
- 1 = With % Capacity

Digit 34 – Programmable Relays

- X = No Programmable Relays
- A = Programmable Relays

Digit 35 – Pump Type

- X = No Pumps and no Contactors
- 1 = No Pumps w/ Single Contactors
- 2 = No Pumps w/ Dual Contactors
- 3 = No Pumps w/ Single Contactors Single High Head Pump
- 4 = No Pumps w/ Dual Contactors Dual High Head Pump
- 5 = Single Standard Head Pump
- 6 = Single High Head Pump
- 7 = Dual Standard Head Pump
- 8 = Dual High Head Pump

Digit 36 – Pump Flow Control

- X = No Pump Flow Control
- A = Pump Flow Controlled by Triple Duty Valve
- B = Pump Flow Controlled by Variable Speed Drive

Digit 37 – Buffer Tank

- X = No Tank
- 1 = With Tank

Digit 38 – Short Circuit Rating

- A = Default A Short Circuit Rating

Digit 39 – Installation Accessories

- 1 = Elastomeric Isolators
- 4 = Neoprene Pads

Digit 40 – Water Strainer

- X = No Strainer
- A = With Water Strainer Factory- Installed

Digit 41 – Sound Attenuator Package

- 1 = Compact
- 3 = Super Quiet
- 4 = Super Quiet with Night Noise Setback
- 5 = Comprehensive Acoustic Package

Digit 42 – Appearance Options

- X = No Appearance Options
- A = Architectural Louvered Panels
- B = Half Louvers
- C = Access Guards
- D = Access Guards and Half Louvers

Digit 43

- X

Digit 44 – Label and Literature Language

- A = Bulgarian
- B = Spanish and English
- C = German
- D = English
- E = French
- H = Dutch SI (Hollandais)
- J = Italian
- L = Danish
- M = Swedish
- N = Norwegian
- P = Polish
- R = Russian
- T = Czech
- U = Greek
- V = Portuguese
- Y = Romanian
- Z = Serbian
- 1 = Slovak
- 2 = Croatian
- 3 = Hungarian

Digit 45 – Phase order + over/under voltage

- X = Not installed
- 1 = Installed

Digit 46 – Shipping Package

- X = No Skid (Standard)
- A = Unit Containerization Package

Digit 47

- X

Digit 48 – Flow switch setpoint

- C = Setpoint 15
- F = Setpoint 35
- H = Setpoint 45
- L = Setpoint 60

Digit 49

- X

Digit 50 – Specials

- X = None
- S = Special

Notes:

1. If a digit is not defined it may be held for future use.

General Data

Table 1. General Data CXAM - Standard Efficiency & Compact - Simplex units

Size		20	23	26	30	35	39	45	50
Eurovent Performances (1)									
Net Cooling Capacity	(kW)	55.5	61.3	69.2	77.5	94.7	109.9	121.0	130.7
Total Power Input in Cooling	(kW)	19.5	22.1	24.1	28.2	32.8	38.3	43.9	49.8
EER		2.8	2.8	2.9	2.7	3.0	2.9	2.8	2.6
Net Heating Capacity	(kW)	61.9	69.1	77.9	87.5	100.8	112.4	124.5	133.6
Total Power Input in Heating	(kW)	21.2	23.7	26.2	29.6	35.5	39.3	43.6	48.1
Heating COP		2.9	2.9	3.0	3.0	2.8	2.9	2.9	2.8
Main Power Supply		400/3/50	400/3/50	400/3/50	400/3/50	400/3/50	400/3/50	400/3/50	400/3/50
Sound Power Level	(dBA)	88	88	88	89	92	93	92	91
System Data									
Refrigerant Circuit	#	1	1	1	1	1	1	1	1
Capacity Steps	%	50-100	43-100	50-100	50-100	43-100	50-100	44-100	50-100
Units Amps									
Nominal Amps (2)	(A)	55	59	63	65	83	93	103	113
Start-up Amps (2)									
Standard Unit	(A)	176	192	196	199	261	272	317	327
With Soft Starter Option	(A)	119	129	133	135	175	186	213	223
Short Circuit Unit Capacity	(kA)	15	15	15	15	15	15	15	15
Max Supply Cable Size	(mm ²)	95	95	95	95	150	150	150	150
Compressor									
Compressor Number per Circuit	#	2	2	2	2	2	2	2	2
Type		Scroll	Scroll	Scroll	Scroll	Scroll	Scroll	Scroll	Scroll
Model		CSHD125 & CSHD125	CSHD125 & CSHD161	CSHD161 & CSHD161	CSHN184 & CSHN184	CSHN184 & CSHN250	CSHN250 & CSHN250	CSHN250 & CSHN315	CSHN315 & CSHN315
Rated Amps per Circuit	(A)	20.7 & 20.7	20.7 & 25	25 & 25	26 & 26	26 & 36.4	36.4 & 36.4	36.4 & 46.4	46.4 & 46.4
Locked Rotor Amps per Circuit	(A)	142 & 142	142 & 158	158 & 158	160 & 160	160 & 215	215 & 215	215 & 260	260 & 260
Motor RPM	(rpm)	2900	2900	2900	2900	2900	2900	2900	2900
Sump heater per circuit	kW	90&90	90&90	90&90	160&160	160&160	160&160	160&160	160&160
Power Factor	#	0.85	0.85	0.85	0.85	0.85	0.85	0.85	0.85
Evaporator									
Quantity	#	1	1	1	1	1	1	1	1
Type		BPHE	BPHE	BPHE	BPHE	BPHE	BPHE	BPHE	BPHE
Water Volume/Storage (Total)	(L)	4.0	4.0	4.0	5.3	8.2	10.6	13.3	13.3
Heater Power	(W)	200	200	200	200	200	300	300	300
Min. Flow	(L/Sec)	1.3	1.4	1.6	1.8	2.2	2.6	2.8	3.0
Max. Flow	(L/Sec)	3.9	4.3	4.8	5.4	6.6	7.7	8.5	9.1
Pump Package (Option Standard Head)									
Evaporator Head Pressure Available Single Pump	(kPa)	92.2	64.0	49.7	77.8	68.7	101.9	97.5	84.1
Evaporator Head Pressure Available Dual Pump	(kPa)	92.2	64.0	49.7	77.8	68.7	101.9	97.5	84.1
Power (3)	(kW)	1.5	1.5	1.5	1.5	1.5	3	3	3
Rated Amps (3)	(A)	3.25	3.25	3.25	3.25	3.25	6.1	6.1	6.1
Pump Package (Option High Head)									
Evaporator Head Pressure Available Single Pump	(kPa)	269.0	240.1	219.0	249.5	234.7	225.9	218.5	200.0
Evaporator Head Pressure Available Dual Pump	(kPa)	269.0	240.1	219.0	249.5	234.7	225.9	218.5	200.0
Power (2)	(kW)	4	4	4	4	5.5	5.5	5.5	5.5
Rated Amps (2)	(A)	7.59	7.59	7.59	7.59	10.6	10.6	10.6	10.6
Hydraulic Module components									
Expansion Tank Volume	(L)	25	25	25	25	25	25	25	0
User Volume Expansion Capacity	(L)	50	50	50	50	50	50	50	50
Max. Water-side Operating Pressure without Hydraulic Module	(kPa)	1000	1000	1000	1000	1000	1000	1000	1000
Max. Water-side Operating Pressure with Hydraulic Module	(kPa)	500	500	500	500	500	500	500	500
Antifreeze Heater without pump package and without strainer	(W)					120			
Antifreeze Heater without pump package and with strainer	(W)					180			
Pump package antifreeze Heater	(W)	530							
Buffer tank antifreeze Heater	(W)					800			
VFD Weight	(kg)	10	10	10	10	10	10	10	10

Table 1. General Data CXAM - Standard Efficiency & Compact - Simplex units

Size		20	23	26	30	35	39	45	50
Water tank Volume	(L)	506	506	506	506	506	506	506	0
Condenser									
Type		Fin and Tube	Fin and Tube	Fin and Tube	Fin and Tube	Fin and Tube	Fin and Tube	Fin and Tube	Fin and Tube
Tube diameter	(mm)	9.52	9.52	9.52	9.52	9.52	9.52	9.52	9.52
Number of Rows	#	3	3	3	3	3	3	3	3
Fins per Foot	(fpf)	192	192	192	192	192	192	192	192
Fan									
Quantity	#	2	2	2	2	3	3	3	3
Diameter	(mm)	732	732	732	732	732	732	732	732
Drive Type		Direct	Direct	Direct	Direct	Direct	Direct	Direct	Direct
Std Amb. Speeds per Circuit (4)		1xD + 1xS	1xD + 1xS	1xD + 1xS	1xD + 1xS	1xD + 2xS	1xD + 2xS	1xD + 2xS	1xD + 2xS
Low Amb. Speeds per Circuit (Option) (4)		1xVFD + 1xS	1xVFD + 1xS	1xVFD + 1xS	1xVFD + 1xS	1xVFD + 2xS	1xVFD + 2xS	1xVFD + 2xS	1xVFD + 2xS
Airflow per Fan	(m ³ /h)	15317	15323	17022	17027	16515	16522	16528	16533
Static Pressure	(Pa)	0	0	0	0	0	0	0	0
Power per Motor	(kW)	1.7	1.7	1.6	1.6	1.7	1.7	1.7	1.7
Rated Amps per Motor	(A)	3.36	3.36	3.36	3.36	3.36	3.36	3.36	3.36
Motor RPM	(rpm)	920	920	920	920	920	920	920	920
PHR									
Heat-Exchanger Type		Brazed Plates	Brazed Plates	Brazed Plates	Brazed Plates	Brazed Plates	Brazed Plates	Brazed Plates	Brazed Plates
Victaulic Connection	(mm)	38	38	38	38	38	38	38	38
Water Storage Capacity	(L)	0.0671	0.0671	0.0671	0.0915	0.0915	0.1098	0.1220	0.1220
Unit Water Connection									
Chilled Water	(mm)	50	50	50	65	65	65	65	65
Type (Standard)		Grooved	Grooved	Grooved	Grooved	Grooved	Grooved	Grooved	Grooved
Dimensions									
Unit Length with Buffer Tank	(mm)	3418	3418	3418	3418	4332	4332	4332	4332
Unit Length with VFD	(mm)	2908	2908	2908	2908	3822	3822	3822	3822
Unit Length with Buffer Tank and VFD	(mm)	3418	3418	3418	3418	4332	4332	4332	4332
Unit Length without Buffer Tank or VFD	(mm)	2908	2908	2908	2908	3822	3822	3822	3822
Unit Width	(mm)	1301	1301	1301	1301	1301	1301	1301	1301
Unit Height	(mm)	2153	2153	2153	2153	2153	2153	2153	2153
Weight (Aluminium Fins without louver or VFD)									
Shipping Weight (5)	(kg)	910	914	938	1032	1260	1268	1325	1372
Operating Weight (5)	(kg)	917	921	946	1042	1272	1283	1342	1389
Additional weight (dual pump high head)	(kg)	199	199	200	200	255	256	255	255
Additional weight (dual pump standard head)	(kg)	183	183	183	184	225	232	231	250
Additional weight (single pump high head)	(kg)	162	162	163	163	208	209	208	208
Additional weight (single pump standard head)	(kg)	153	153	154	154	195	199	198	207
Additional weight (Buffer tank)	(kg)	188	188	188	188	189	188	188	188
Louver Weight	(kg)	19	19	19	19	25	25	25	25
Min. Starting/Oper. Ambient									
Std Unit	(°C)	7	7	7	7	7	7	7	7
Low Ambient (Option)	(°C)	-18	-18	-18	-18	-18	-18	-18	-18
Refrigerant and Oil charge per circuit									
Refrigerant charge	(Kg)	19.1	19.1	22.7	22.7	32.7	32.7	32.7	33.6
Oil Charge	(L)	6.6	6.6	6.6	13.4	13.4	13.4	13.4	6.6

(1) Eurovent Cooling Mode Conditions (Evap. 12°C/7°C - Air. 35°C); Eurovent Heating Mode Condition (Evap. 40°C/45°C-Air. DB/WB 7°C/6°C)

(2) Rated Condition without Pump Package

(3) Single Pump Option

(4) S: Single Speed, D: Two Speed, VFD: Inverter.

(5) Base unit



General Data

Table 2. General Data - CXAM Standard Efficiency & Compact - Duplex V units

Size		40	46	52	60	70	80	90
Eurovent Performances (1)								
Net Cooling Capacity	(kW)	111.9	126.2	143.8	161.1	191.4	223.6	247.7
Total Power Input in Cooling	(kW)	39.0	44.6	48.9	56.8	67.7	76.8	88.1
EER		2.9	2.8	2.9	2.8	2.8	2.9	2.8
Net Heating Capacity	(kW)	125.7	141.4	159.8	177.2	203.1	227.5	251.4
Total Power Input in Heating	(kW)	42.6	46.6	51.5	58.7	71.0	79.1	87.7
Heating COP		3.0	3.0	3.1	3.0	2.9	2.9	2.9
Main Power Supply		400/3/50	400/3/50	400/3/50	400/3/50	400/3/50	400/3/50	400/3/50
Sound Power Level	(dBA)	91	91	91	92	95	96	95
System Data								
Refrigerant Circuit	#	2	2	2	2	2	2	2
Capacity Steps	%	25-50-75-100	21-43-71-100	25-50-75-100	25-50-75-100	21-43-71-100	25-50-75-100	22-44-72-100
Units Amps								
Nominal Amps (2)	(A)	96	105	113	117	145	166	186
Start-up Amps (2)								
Standard Unit	(A)	218	238	246	251	324	344	399
With Soft Starter Option	(A)	161	175	183	187	238	258	295
Short Circuit Unit Capacity	(kA)	15	15	15	15	15	15	15
Max Supply Cable Size	(mm ²)	150	150	150	240	240	240	240
Compressor								
Compressor Number per Circuit	#	2	2	2	2	2	2	2
Type		Scroll	Scroll	Scroll	Scroll	Scroll	Scroll	Scroll
Model		CSHD125 & CSHD125	CSHD125 & CSHD161	CSHD161 & CSHD161	CSHN184 & CSHN184	CSHN184 & CSHN250	CSHN250 & CSHN250	CSHN250 & CSHN315
Rated Amps per Circuit	(A)	20.7 & 20.7	20.7 & 25	25 & 25	26 & 26	26 & 36.4	36.4 & 36.4	36.4 & 46.4
Locked Rotor Amps per Circuit	(A)	142 & 142	142 & 158	158 & 158	160 & 160	160 & 215	215 & 215	215 & 260
Motor RPM	(rpm)	2900	2900	2900	2900	2900	2900	2900
Sump heater per circuit	kW	160&160	160&160	160&160	160&160	160&160	160&160	160&160
Power Factor	#	0.85	0.85	0.85	0.85	0.85	0.85	0.85
Evaporator								
Quantity	#	1	1	1	1	1	1	1
Type		BPHE	BPHE	BPHE	BPHE	BPHE	BPHE	BPHE
Water Volume/Storage (Total)	(L)	9.1	14.3	14.3	15.6	21.5	24.0	28.2
Heater Power	(W)	200	300	300	300	400	400	400
Min. Flow	(L/Sec)	2.6	2.9	3.3	3.7	4.4	5.2	5.7
Max. Flow	(L/Sec)	7.7	8.6	9.9	11.1	13.3	15.5	17.1
Pump Package (Option Standard Head)								
Evaporator Head Pressure Available Single Pump	(kPa)	68.1	99.9	74.6	100.7	126.4	105.5	124.3
Evaporator Head Pressure Available Dual Pump	(kPa)	68.1	99.9	74.6	100.7	126.4	105.5	124.3
Power (3)	(kW)	3	4	4	4	5.5	5.5	5.5
Rated Amps (3)	(A)	6.1	7.59	7.59	7.59	10.6	10.6	10.6
Pump Package (Option High Head)								
Evaporator Head Pressure Available Single Pump	(kPa)	221.9	219.3	185.3	212.2	203.2	182.2	202.6
Evaporator Head Pressure Available Dual Pump	(kPa)	221.9	219.3	185.3	212.2	203.2	182.2	202.6
Power (2)	(kW)	5.5	5.5	5.5	7.5	7.5	7.5	7.5
Rated Amps (2)	(A)	10.6	10.6	10.6	13.8	13.8	13.8	13.8
Hydraulic Module components								
Expansion Tank Volume	(L)	25	25	25	25	25	25	25
User Volume Expansion Capacity	(L)	50	50	50	50	50	50	50
Max. Water-side Operating Pressure without Hydraulic Module	(kPa)	1000	1000	1000	1000	1000	1000	1000
Max. Water-side Operating Pressure with Hydraulic Module	(kPa)	500	500	500	500	500	500	500
Antifreeze Heater without pump package and without strainer	(W)				120			
Antifreeze Heater without pump package and with strainer	(W)				120			
Pump package antifreeze Heater	(W)				860			
Buffer tank antifreeze Heater	(W)				800			
VFD Weight	(kg)	15	15	15	15	15	15	15
Water tank Volume	(L)	500	500	500	500	500	500	500

Table 2. General Data - CXAM Standard Efficiency & Compact - Duplex V units

Size		40	46	52	60	70	80	90
Condenser								
Type		Fin and Tube	Fin and Tube	Fin and Tube	Fin and Tube	Fin and Tube	Fin and Tube	Fin and Tube
Tube diameter	(mm)	9.52	9.52	9.52	9.52	9.52	9.52	9.52
Number of Rows	#	3	3	3	3	3	3	3
Fins per Foot	(fpf)	192	192	192	192	192	192	192
Fan								
Quantity	#	4	4	4	4	6	6	6
Diameter	(mm)	732	732	732	732	732	732	732
Drive Type		Direct	Direct	Direct	Direct	Direct	Direct	Direct
Std Amb. Speeds per Circuit (4)		1xD + 1xS	1xD + 1xS	1xD + 1xS	1xD + 1xS	1xD + 2xS	1xD + 2xS	1xD + 2xS
Low Amb. Speeds per Circuit (Option) (4)		1xVFD + 1xS	1xVFD + 1xS	1xVFD + 1xS	1xVFD + 1xS	1xVFD + 2xS	1xVFD + 2xS	1xVFD + 2xS
Airflow per Fan	(m ³ /h)	15317	15324	17023	17028	15284	16523	16529
Static Pressure	(Pa)	0	0	0	0	0	0	0
Power per Motor	(kW)	1.7	1.7	1.6	1.6	1.7	1.7	1.7
Rated Amps per Motor	(A)	3.36	3.36	3.36	3.36	3.36	3.36	3.36
Motor RPM	(rpm)	920	920	920	920	920	920	920
PHR								
Heat-Exchanger Type		Brazed Plates	Brazed Plates	Brazed Plates	Brazed Plates	Brazed Plates	Brazed Plates	Brazed Plates
Victaulic Connection	(mm)	38	38	38	38	38	38	38
Water Storage Capacity	(L)	0.0671*2	0.0671*2	0.0671*2	0.0915*2	0.0915*2	0.1098*2	0.122*2
Unit Water Connection								
Chilled Water	(mm)	65	65	65	80	80	80	80
Type (Standard)		Grooved	Grooved	Grooved	Grooved	Grooved	Grooved	Grooved
Dimensions								
Unit Length with Buffer Tank	(mm)	3416	3416	3416	3416	4330	4330	4330
Unit Length with VFD	(mm)	3193	3193	3193	3193	4107	4107	4107
Unit Length with Buffer Tank and VFD	(mm)	3704	3704	3704	3704	4618	4618	4618
Unit Length without Buffer Tank or VFD	(mm)	2905	2905	2905	2905	3819	3819	3819
Unit Width	(mm)	2266	2266	2266	2266	2266	2266	2266
Unit Height	(mm)	2150	2150	2150	2150	2150	2150	2150
Weight (Aluminium Fins without louver or VFD)								
Shipping Weight (5)	(kg)	1652	1679	1728	1910	2171	2220	2327
Operating Weight (5)	(kg)	1665	1697	1746	1928	2196	2247	2358
Additional weight (dual pump high head)	(kg)	226	225	226	316	319	319	319
Additional weight (dual pump standard head)	(kg)	209	221	221	221	237	237	237
Additional weight (single pump high head)	(kg)	179	178	179	220	222	222	222
Additional weight (single pump standard head)	(kg)	171	177	177	177	186	186	186
Additional weight (Buffer tank)	(kg)	189	188	188	188	189	189	189
Louver Weight	(kg)	32	32	32	32	37	37	37
Min. Starting/Oper. Ambient								
Std Unit	(°C)	7	7	7	7	7	7	7
Low Ambient (Option)	(°C)	-18	-18	-18	-18	-18	-18	-18
Refrigerant and Oil charge per circuit								
Refrigerant charge	(Kg)	19.1	19.1	22.7	22.7	29	31.8	33.6
Oil Charge	(L)	13.4	6.6	6.6	13.4	13.4	13.4	13.4

(1) Eurovent Cooling Mode Conditions (Evap. 12°C/7°C - Air. 35°C); Eurovent Heating Mode Condition (Evap. 40°C/45°C-Air. DB/WB 7°C/6°C)

(2) Rated Condition without Pump Package

(3) Single Pump Option

(4) S: Single Speed, D: Two Speed, VFD: Inverter.

(5) Base unit



General Data

Table 3. General Data - CXAM Standard Efficiency & Compact - Duplex W units

Size		100	110	120	140	150	160	170
Eurovent Performances (1)								
Net Cooling Capacity	(kW)	276.3	295.0	317.4	376.5	399.7	432.6	450.6
Total Power Input in Cooling	(kW)	95.2	104.2	114.6	138.1	150.2	155.8	165.3
EER		2.9	2.8	2.8	2.7	2.7	2.8	2.7
Net Heating Capacity	(kW)	271.1	287.0	301.7	360.7	375.0	427.7	442.7
Total Power Input in Heating	(kW)	95.5	102.8	109.4	136.6	144.7	157.4	165.1
Heating COP		2.8	2.8	2.8	2.6	2.6	2.7	2.7
Main Power Supply		400/3/50	400/3/50	400/3/50	400/3/50	400/3/50	400/3/50	400/3/50
Sound Power Level	(dBA)	92	93	93	95	94	95	95
System Data								
Refrigerant Circuit	#	2	2	2	2	2	2	2
Capacity Steps	%	25-50-75-100	23-45-73-100	25-50-75-100	14-29-46-64-82-100	17-33-50-67-83-100	16-31-47-63-81-100	15-29-47-65-82-100
Units Amps								
Nominal Amps (2)	(A)	206	226	246	292	312	339	359
Start-up Amps (2)								
Standard Unit	(A)	419	489	509	506	526	602	622
With Soft Starter Option	(A)	315	361	381	402	422	474	494
Short Circuit Unit Capacity	(kA)	15	15	15	15	15	15	15
Max Supply Cable Size	(mm ²)	240	240	240	2 x 300	2 x 300	2 x 300	2 x 300
Compressor								
Compressor Number per Circuit	#	2	2	2	3	3	3	3
Type		Scroll	Scroll	Scroll	Scroll	Scroll	Scroll	Scroll
Model		CSHN315 & CSHN315	CSHN315 & CSHN374	CSHN374 & CSHN374	CSHN250 & CSHN315 & CSHN315	CSHN315 & CSHN315 & CSHN315	CSHN315 & CSHN315 & CSHN374	CSHN315 & CSHN374 & CSHN374
Rated Amps per Circuit	(A)	46.4 & 46.4	46.4 & 56.4	56.4 & 56.4	36.4 & 46.4 & 46.4	46.4 & 46.4 & 46.4	46.4 & 46.4 & 56.4	46.4 & 56.4 & 56.4
Locked Rotor Amps per Circuit	(A)	260 & 260	260 & 320	320 & 320	215 & 260 & 260	260 & 260 & 260	320 & 320 & 320	260 & 320 & 320
Motor RPM	(rpm)	2900	2900	2900	2900	2900	2900	2900
Sump heater per circuit	kW	160&160	160&160	160&160	160&160	160&160	160&160	160&160
Power Factor	#	0.85	0.85	0.85	0.85	0.85	0.85	0.85
Evaporator								
Quantity	#	1	1	1	1	1	1	1
Type		BPHE	BPHE	BPHE	BPHE	BPHE	BPHE	BPHE
Water Volume/Storage (Total)	(L)	32.4	32.4	39.2	40.8	46.7	46.7	46.7
Heater Power	(W)	400	400	500	500	500	500	500
Min. Flow	(L/Sec)	6.4	6.8	7.3	8.7	9.2	10.0	10.4
Max. Flow	(L/Sec)	19.1	20.4	22.0	26.1	27.7	30.0	31.3
Pump Package (Option Standard Head)								
Evaporator Head Pressure Available Single Pump	(kPa)	119.8	122.3	124.5	146.2	132.9	113.5	102.2
Evaporator Head Pressure Available Dual Pump	(kPa)	119.8	122.3	124.5	146.2	132.9	113.5	102.2
Power (3)	(kW)	5.5	7.5	7.5	11	11	11	11
Rated Amps (3)	(A)	10.6	13.8	13.8	19.6	19.6	19.6	19.6
Pump Package (Option High Head)								
Evaporator Head Pressure Available Single Pump	(kPa)	203.2	190.4	232.2	204.1	190.4	226.5	215.1
Evaporator Head Pressure Available Dual Pump	(kPa)	203.2	190.4	232.2	204.1	190.4	226.5	215.1
Power (2)	(kW)	7.5	7.5	11	11	11	15	15
Rated Amps (2)	(A)	13.8	13.8	19.6	19.6	19.6	26.5	26.5
Hydraulic Module components								
Expansion Tank Volume	(L)	60	60	60	60	60	60	60
User Volume Expansion Capacity	(L)	900	900	900	900	900	900	900
Max. Water-side Operating Pressure without Hydraulic Module	(kPa)	1000	1000	1000	1000	1000	1000	1000
Max. Water-side Operating Pressure with Hydraulic Module	(kPa)	500	500	500	500	500	500	500
Antifreeze Heater without pump package and without strainer	(W)	120	120	120	240	240	240	240
Antifreeze Heater without pump package and with strainer	(W)	240	240	240	300	300	300	300
Pump package antifreeze Heater	(W)	980	980	980	1100	1100	1100	1100
Buffer tank antifreeze Heater	(W)	1200	1200	1200	1200	1200	1200	1200

Table 3. General Data - CXAM Standard Efficiency & Compact - Duplex W units

Size		100	110	120	140	150	160	170
VFD Weight	(kg)	21	21	21	21	21	21	21
Water tank Volume	(L)	725	725	725	725	725	725	725
Condenser								
Type		Fin and Tube	Fin and Tube	Fin and Tube	Fin and Tube	Fin and Tube	Fin and Tube	Fin and Tube
Tube diameter	(mm)	9.52	9.52	9.52	9.52	9.52	9.52	9.52
Number of Rows	#	3	3	3	3	3	3	3
Fins per Foot	(fpf)	192	192	192	192	192	192	192
Fan								
Quantity	#	6	6	6	10	10	12	12
Diameter	(mm)	732	732	732	732	732	732	732
Drive Type		Direct	Direct	Direct	Direct	Direct	Direct	Direct
Std Amb. Speeds per Circuit (4)		1×D + 2×S	1×D + 2×S	1×D + 2×S	5×S	5×S	6×S	6×S
Low Amb. Speeds per Circuit (Option) (4)		1×VFD + 2×S	1×VFD + 2×S	1×VFD + 2×S	1×VFD + 4×S	1×VFD + 4×S	1×VFD + 5×S	1×VFD + 5×S
Airflow per Fan	(m ³ /h)	18498	18950	18951	17594	17596	17593	17594
Static Pressure	(Pa)	0	0	0	0	0	0	0
Power per Motor	(kW)	1.6	1.5	1.5	1.6	1.6	1.6	1.6
Rated Amps per Motor	(A)	3.36	3.36	3.36	3.36	3.36	3.36	3.36
Motor RPM	(rpm)	920	920	920	920	920	920	920
PHR								
Heat-Exchanger Type		Brazed Plates	Brazed Plates	Brazed Plates	Brazed Plates	Brazed Plates	Brazed Plates	Brazed Plates
Victaulic Connection	(mm)	64	64	64	64	64	64	64
Water Storage Capacity	(L)	0.122*2	0.1647*2	0.1647*2	0.2135*2	0.2135*2	0.2135*2	0.2135*2
Unit Water Connection								
Chilled Water	(mm)	100	100	100	100	100	100	100
Type (Standard)		Grooved	Grooved	Grooved	Grooved	Grooved	Grooved	Grooved
Dimensions								
Unit Length with Buffer Tank	(mm)	4230	4230	4230	5145	5145	6062	6062
Unit Length with VFD	(mm)	4558	4558	4558	5473	5473	6388	6388
Unit Length with Buffer Tank and VFD	(mm)	4558	4558	4558	5473	5473	6388	6388
Unit Length without Buffer Tank or VFD	(mm)	4230	4230	4230	5145	5145	6062	6062
Unit Width	(mm)	2273	2273	2273	2273	2273	2273	2273
Unit Height	(mm)	2344	2344	2344	2344	2344	2344	2344
Weight (Aluminium Fins without louver or VFD)								
Shipping Weight (5)	(kg)	2773	2773	2794	3457	3570	3956	3956
Operating Weight (5)	(kg)	2808	2808	2835	3500	3618	4005	4005
Additional weight (dual pump high head)	(kg)	406	406	488	511	510	583	583
Additional weight (dual pump standard head)	(kg)	325	405	405	510	510	556	556
Additional weight (single pump high head)	(kg)	310	310	355	377	377	436	436
Additional weight (single pump standard head)	(kg)	274	314	314	377	376	423	423
Additional weight (Buffer tank)	(kg)	188	188	188	188	188	188	188
Louver Weight	(kg)	47	47	47	51	51	56	56
Min. Starting/Oper. Ambient								
Std Unit	(°C)	7	7	7	7	7	7	7
Low Ambient (Option)	(°C)	-18	-18	-18	-18	-18	-18	-18
Refrigerant and Oil charge per circuit								
Refrigerant charge	(Kg)	46.3	48.1	46.3	57.2	57.2	68.9	67.1
Oil Charge	(L)	13.4	13.9	14.4	22.5	23	23.5	24

(1) Eurovent Cooling Mode Conditions (Evap. 12°C/7°C - Air. 35°C); Eurovent Heating Mode Condition (Evap. 40°C/45°C-Air. DB/WB 7°C/6°C)
(2) Rated Condition without Pump Package
(3) Single Pump Option
(4) S: Single Speed, D: Two Speed, VFD: Inverter.
(5) Base unit



General Data

Table 4. General Data - CXAM Standard Efficiency & Super Quiet - Simplex units

Size	20	23	26	30	35	39	45	50	
Eurovent Performances (1)									
Net Cooling Capacity	(kW)	54.5	60.0	68.3	76.1	93.4	107.8	118.5	127.3
Total Power Input in Cooling	(kW)	18.9	21.9	23.9	28.2	32.2	38.0	44.1	50.3
EER		2.9	2.7	2.9	2.7	2.9	2.8	2.7	2.5
Net Heating Capacity	(kW)	60.8	67.8	76.9	86.1	99.4	110.7	122.2	131.2
Total Power Input in Heating	(kW)	19.6	22.2	25.0	28.2	33.5	37.3	41.5	46.1
Heating COP		3.1	3.1	3.1	3.1	3.0	3.0	2.9	2.8
Main Power Supply		400/3/50	400/3/50	400/3/50	400/3/50	400/3/50	400/3/50	400/3/50	400/3/50
Sound Power Level	(dBA)	83	83	83	83	86	87	86	85
System Data									
Refrigerant Circuit	#	1	1	1	1	1	1	1	1
Capacity Steps	%	50-100	43-100	50-100	50-100	43-100	50-100	44-100	50-100
Units Amps									
Nominal Amps (2)	(A)	54	58	62	64	81	92	102	112
Start-up Amps (2)									
Standard Unit	(A)	175	191	195	198	260	270	315	325
With Soft Starter Option	(A)	118	128	132	134	174	184	211	221
Short Circuit Unit Capacity	(kA)	15	15	15	15	15	15	15	15
Max Supply Cable Size	(mm ²)	95	95	95	95	150	150	150	150
Compressor									
Compressor Number per Circuit	#	2	2	2	2	2	2	2	2
Type		Scroll	Scroll	Scroll	Scroll	Scroll	Scroll	Scroll	Scroll
Model		CSHD125 & CSHD125	CSHD125 & CSHD161	CSHD161 & CSHD161	CSHN184 & CSHN184	CSHN184 & CSHN250	CSHN250 & CSHN250	CSHN315 & CSHN315	CSHN315 & CSHN315
Number of Speeds	#	1	1	1	1	1	1	1	1
Motor Number per Circuit	#	2	2	2	2	2	2	2	2
Rated Amps per Circuit	(A)	20.7 & 20.7	20.7 & 25	25 & 25	26 & 26	26 & 36.4	36.4 & 36.4	36.4 & 46.4	46.4 & 46.4
Locked Rotor Amps per Circuit	(A)	142 & 142	142 & 158	158 & 158	160 & 160	160 & 215	215 & 215	215 & 260	260 & 260
Motor RPM	(rpm)	2900	2900	2900	2900	2900	2900	2900	2900
Sump heater per circuit	kW	90890	90890	90890	1608160	1608160	1608160	1608160	1608160
Power Factor	#	0.85	0.85	0.85	0.85	0.85	0.85	0.85	0.85
Evaporator									
Quantity	#	1	1	1	1	1	1	1	1
Type		BPHE	BPHE	BPHE	BPHE	BPHE	BPHE	BPHE	BPHE
Model		P80	P80	P80	P80	P1201	P1201	P1201	P1201
Water Volume/Storage (Total)	(L)	4.0	4.0	4.0	5.3	8.2	10.6	13.3	13.3
Heater Power	(W)	200	200	200	200	200	300	300	300
Min. Flow	(L/Sec)	1.3	1.4	1.6	1.8	2.2	2.5	2.8	3.0
Max. Flow	(L/Sec)	3.8	4.2	4.8	5.3	6.5	7.5	8.3	8.9
Pump Package (Option Standard Head)									
Evaporator Head Pressure Available Single Pump	(kPa)	93.8	66.9	47.1	79.8	70.6	104.6	101.0	88.9
Evaporator Head Pressure Available Dual Pump	(kPa)	93.8	66.9	47.1	79.8	70.6	104.6	101.0	88.9
Pump Type (Single)		Vertical Pump	Vertical Pump	Vertical Pump	Vertical Pump	Vertical Pump	Vertical Pump	Vertical Pump	Vertical Pump
Model (Single)		IPL50/120-1.5/2-N66-TRANE	IPL50/120-1.5/2-N66-TRANE	IPL50/120-1.5/2-N66-TRANE	IPL50/120-1.5/2-N66-TRANE	IPL50/120-1.5/2-N66-TRANE	IPL50/130-3/2-N31-N66-TRANE	IPL50/130-3/2-N31-N66-TRANE	IPL50/130-3/2-N31-N66-TRANE
Pump Type (Dual)		Vertical Pump	Vertical Pump	Vertical Pump	Vertical Pump	Vertical Pump	Vertical Pump	Vertical Pump	Vertical Pump
Model (Dual)		DPL50/120-1.5/2-N66-TRANE	DPL50/120-1.5/2-N66-TRANE	DPL50/120-1.5/2-N66-TRANE	DPL50/120-1.5/2-N66-TRANE	DPL50/120-1.5/2-N66-TRANE	DPL50/130-3/2-N31-N66-TRANE	DPL50/130-3/2-N31-N66-TRANE	DPL50/130-3/2-N31-N66-TRANE
Pump Set Number	#	1	1	1	1	1	1	1	1
Power (3)	(kW)	1.5	1.5	1.5	1.5	1.5	3	3	3
Rated Amps (3)	(A)	3.25	3.25	3.25	3.25	3.25	6.1	6.1	6.1
Start-up Amps (3)	(A)	19.1	19.1	19.1	19.1	19.1	38.0	38.0	38.0
Motor RPM	(rpm)	2860	2860	2860	2860	2860	2890	2890	2890
Pump Package (Option High Head)									
Evaporator Head Pressure Available Single Pump	(kPa)	270.6	243.4	221.6	251.9	237.0	229.1	223.2	206.3
Evaporator Head Pressure Available Dual Pump	(kPa)	270.6	243.4	221.6	251.9	237.0	229.1	223.2	206.3
Pump Type (Single)		Vertical Pump	Vertical Pump	Vertical Pump	Vertical Pump	Vertical Pump	Vertical Pump	Vertical Pump	Vertical Pump
Model (Single)		IPL40/160-4/2-N66-TRANE	IPL40/160-4/2-N66-TRANE	IPL40/160-4/2-N66-TRANE	IPL40/160-4/2-N66-TRANE	IPL40/160-5.5/2-N31-N66-TRANE	IPL40/160-5.5/2-N31-N66-TRANE	IPL40/160-5.5/2-N31-N66-TRANE	IPL40/160-5.5/2-N31-N66-TRANE
Pump Type (Dual)		Vertical Pump	Vertical Pump	Vertical Pump	Vertical Pump	Vertical Pump	Vertical Pump	Vertical Pump	Vertical Pump
Model (Dual)		DPL40/160-4/2-N66-TRANE	DPL40/160-4/2-N66-TRANE	DPL40/160-4/2-N66-TRANE	DPL40/160-4/2-N66-TRANE	DPL40/160-5.5/2-N31-N66-TRANE	DPL40/160-5.5/2-N31-N66-TRANE	DPL40/160-5.5/2-N31-N66-TRANE	DPL40/160-5.5/2-N31-N66-TRANE
Pump Set Number	#	1	1	1	1	1	1	1	1
Power (3)	(kW)	4	4	4	4	5.5	5.5	5.5	5.5
Rated Amps (3)	(A)	7.59	7.59	7.59	7.59	10.6	10.6	10.6	10.6
Start-up Amps (3)	(A)	49.7	49.7	49.7	49.7	85	85	85	85
Motor RPM	(rpm)	2890	2890	2890	2890	2890	2890	2890	2890
Hydraulic Module components									
Water strainer Ø	(mm)	50	50	50	65	65	65	65	65
Expansion Tank Volume	(L)	25	25	25	25	25	25	25	25
User Volume Expansion Capacity	(L)	50	50	50	50	50	50	50	50
Max. Water-side Operating Pressure without Hydraulic Module	(kPa)	1000	1000	1000	1000	1000	1000	1000	1000
Max. Water-side Operating Pressure with Hydraulic Module	(kPa)	500	500	500	500	500	500	500	500
Antifreeze Heater without pump package and without strainer	(W)	120							

Table 4. General Data - CXAM Standard Efficiency & Super Quiet - Simplex units

Size	20	23	26	30	35	39	45	50
Antifreeze Heater without pump package and with strainer (W)					180			
Pump package antifreeze Heater (W)					530			
Buffer tank antifreeze Heater (W)					800			
VFD Weight (kg)	10	10	10	10	10	10	10	10
Water tank Volume (L)	506	506	506	506	506	506	506	506
Condenser								
Type	Fin and Tube	Fin and Tube	Fin and Tube	Fin and Tube	Fin and Tube	Fin and Tube	Fin and Tube	Fin and Tube
Tube Type	IF	IF	IF	IF	IF	IF	IF	IF
Tube diameter (mm)	9.52	9.52	9.52	9.52	9.52	9.52	9.52	9.52
Qty of Coils	1	1	1	1	1	1	1	1
Coil Length (mm)	1854	1854	2311	2311	3226	3226	3226	3226
Coil Height per Circuit (mm)	1727	1727	1727	1727	1727	1727	1727	1727
Number of Rows	3	3	3	3	3	3	3	3
Fins per Foot (fpf)	192	192	192	192	192	192	192	192
Fan								
Type	Propeller	Propeller	Propeller	Propeller	Propeller	Propeller	Propeller	Propeller
Quantity	2	2	2	2	3	3	3	3
Diameter (mm)	762	762	762	762	762	762	762	762
Drive Type	Direct	Direct	Direct	Direct	Direct	Direct	Direct	Direct
Std Amb. Speeds per Circuit (4)	1xD + 1xS	1xD + 1xS	1xD + 1xS	1xD + 1xS	1xD + 2xS	1xD + 2xS	1xD + 2xS	1xD + 2xS
Low Amb. Speeds per Circuit (Option) (4)	1xVFD + 1xS	1xVFD + 1xS	1xVFD + 1xS	1xVFD + 1xS	1xVFD + 2xS	1xVFD + 2xS	1xVFD + 2xS	1xVFD + 2xS
Airflow per Fan (m3/h)	12074	12084	14443	14452	13753	13766	13776	13786
Static Pressure (Pa)	0	0	0	0	0	0	0	0
Motor Number	2	2	2	2	3	3	3	3
Power per Motor (kW)	1.1	1.1	1.2	1.2	1.2	1.2	1.2	1.1
Rated Amps per Motor (A)	3.12	3.12	3.12	3.12	3.12	3.12	3.12	3.12
Motor RPM (rpm)	700	700	700	700	700	700	700	700
Tip Speed (m/s)	28	28	28	28	28	28	28	28
PHR								
Heat-Exchanger Type	Brazed Plates	Brazed Plates	Brazed Plates	Brazed Plates	Brazed Plates	Brazed Plates	Brazed Plates	Brazed Plates
Victaulic Connection (mm)	38	38	38	38	38	38	38	38
Water Storage Capacity (L)	0.0671	0.0671	0.0671	0.0915	0.0915	0.1098	0.1220	0.1220
Unit Water Connection								
Chilled Water (mm)	50	50	50	65	65	65	65	65
Type (Standard)	Grooved	Grooved	Grooved	Grooved	Grooved	Grooved	Grooved	Grooved
Type (Option)	Flange	Flange	Flange	Flange	Flange	Flange	Flange	Flange
Dimensions								
Unit Length with Buffer Tank (mm)	3418	3418	3418	3418	4332	4332	4332	4332
Unit Length with VFD (mm)	2908	2908	2908	2908	3822	3822	3822	3822
Unit Length with Buffer Tank and VFD (mm)	3418	3418	3418	3418	4332	4332	4332	4332
Unit Length without Buffer Tank or VFD (mm)	2908	2908	2908	2908	3822	3822	3822	3822
Unit Width (mm)	1301	1301	1301	1301	1301	1301	1301	1301
Unit Height (mm)	2153	2153	2153	2153	2153	2153	2153	2153
Weight (Aluminium Fins without louver or VFD)								
Shipping Weight (5) (kg)	910	914	938	1032	1260	1268	1325	1372
Operating Weight (5) (kg)	917	921	946	1042	1272	1283	1342	1389
Additional weight (dual pump high head) (kg)	199	199	200	200	255	256	255	255
Additional weight (dual pump standard head) (kg)	183	183	183	184	225	232	231	250
Additional weight (single pump high head) (kg)	162	162	163	163	208	209	208	208
Additional weight (single pump standard head) (kg)	153	153	154	154	195	199	198	207
Additional weight (Buffer tank) (kg)	188	188	188	188	189	188	188	188
Louver Weight (kg)	19	19	19	19	25	25	25	25
Min. Starting/Oper. Ambient								
Std Unit (°C)	7	7	7	7	7	7	7	7
Low Ambient (Option) (°C)	-18	-18	-18	-18	-18	-18	-18	-18
Extreme Low Ambient (Option) (°C)	-29	-29	-29	-29	-29	-29	-29	-29
Refrigerant and Oil charge per circuit								
Refrigerant charge (Kg)	19.1	19.1	22.7	22.7	32.7	32.7	33.6	33.6
Oil Charge (L)	6.6	6.6	6.6	13.4	13.4	13.4	13.4	6.6

(1) Eurovent Cooling Mode Conditions (Evap. 12°C/7°C - Air. 35°C); Eurovent Heating Mode Condition (Evap. 40°C/45°C-Air. DB/WB 7°C/6°C)

(2) Rated Condition without Pump Package

(3) Single Pump Option

(4) S: Single Speed, D: Two Speed, VFD: Inverter.

(5) Base unit



General Data

Table 5. General Data - CXAM Standard Efficiency & Super Quiet - Duplex V units

Size		40	46	52	60	70	80	90
Eurovent Performances (1)								
Net Cooling Capacity	(kW)	109.8	123.4	141.7	158.2	187.1	219.5	242.0
Total Power Input in Cooling	(kW)	37.9	44.0	48.3	56.8	67.0	76.5	88.5
EER		2.9	2.8	2.9	2.8	2.8	2.9	2.7
Net Heating Capacity	(kW)	123.3	138.5	157.5	174.7	198.9	223.9	246.8
Total Power Input in Heating	(kW)	39.5	43.6	49.0	56.2	66.4	74.9	83.6
Heating COP		3.1	3.2	3.2	3.1	3.0	3.0	3.0
Main Power Supply		400/3/50	400/3/50	400/3/50	400/3/50	400/3/50	400/3/50	400/3/50
Sound Power Level	(dBA)	85	85	86	86	89	90	89
System Data								
Refrigerant Circuit	#	2	2	2	2	2	2	2
Capacity Steps	%	25-50-75-100	21-43-71-100	25-50-75-100	25-50-75-100	21-43-71-100	25-50-75-100	22-44-72-100
Units Amps								
Nominal Amps (2)	(A)	95	104	112	116	144	164	184
Start-up Amps (2)								
Standard Unit	(A)	217	237	245	250	322	343	398
With Soft Starter Option	(A)	160	174	182	186	236	257	294
Short Circuit Unit Capacity	(kA)	15	15	15	15	15	15	15
Max Supply Cable Size	(mm ²)	150	150	150	240	240	240	240
Compressor								
Compressor Number per Circuit	#	2	2	2	2	2	2	2
Type		Scroll	Scroll	Scroll	Scroll	Scroll	Scroll	Scroll
Model		CSHD125 & CSHD125	CSHD125 & CSHD161	CSHD161 & CSHD161	CSHN184 & CSHN184	CSHN184 & CSHN250	CSHN250 & CSHN250	CSHN250 & CSHN315
Rated Amps per Circuit	(A)	20.7 & 20.7	20.7 & 25	25 & 25	26 & 26	26 & 36.4	36.4 & 36.4	36.4 & 46.4
Locked Rotor Amps per Circuit	(A)	142 & 142	142 & 158	158 & 158	160 & 160	160 & 215	215 & 215	215 & 260
Motor RPM	(rpm)	2900	2900	2900	2900	2900	2900	2900
Sump heater per circuit	kW	160&160	160&160	160&160	160&160	160&160	160&160	160&160
Power Factor	#	0.85	0.85	0.85	0.85	0.85	0.85	0.85
Evaporator								
Quantity	#	1	1	1	1	1	1	1
Type		BPHE	BPHE	BPHE	BPHE	BPHE	BPHE	BPHE
Water Volume/Storage (Total)	(L)	9.1	14.3	14.3	15.6	21.5	24.0	28.2
Heater Power	(W)	200	300	300	300	400	400	400
Min. Flow	(L/Sec)	2.5	2.8	3.3	3.6	4.3	5.1	5.6
Max. Flow	(L/Sec)	7.5	8.5	9.8	10.9	12.9	15.2	16.8
Pump Package (Option Standard Head)								
Evaporator Head Pressure Available Single Pump	(kPa)	71.0	103.5	77.6	103.6	130.1	109.1	129.6
Evaporator Head Pressure Available Dual Pump	(kPa)	71.0	103.5	77.6	103.6	130.1	109.1	129.6
Power (3)	(kW)	3	4	4	4	5.5	5.5	5.5
Rated Amps (3)	(A)	6.1	7.59	7.59	7.59	10.6	10.6	10.6
Pump Package (Option High Head)								
Evaporator Head Pressure Available Single Pump	(kPa)	225.2	224.1	189.3	214.2	206.7	186.0	206.4
Evaporator Head Pressure Available Dual Pump	(kPa)	225.2	224.1	189.3	214.2	206.7	186.0	206.4
Power (3)	(kW)	5.5	5.5	5.5	7.5	7.5	7.5	7.5
Rated Amps (3)	(A)	10.6	10.6	10.6	13.8	13.8	13.8	13.8
Hydraulic Module components								
Expansion Tank Volume	(L)	25	25	25	25	25	25	25
User Volume Expansion Capacity	(L)	50	50	50	50	50	50	50
Max. Water-side Operating Pressure without Hydraulic Module	(kPa)	1000	1000	1000	1000	1000	1000	1000
Max. Water-side Operating Pressure with Hydraulic Module	(kPa)	500	500	500	500	500	500	500
Antifreeze Heater without pump package and without strainer	(W)				120			
Antifreeze Heater without pump package and with strainer	(W)				120			
Pump package antifreeze Heater	(W)				860			
Buffer tank antifreeze Heater	(W)				800			
VFD Weight	(kg)	15	15	15	15	15	15	15
Water tank Volume	(L)	500	500	500	500	500	500	500

Table 5. General Data - CXAM Standard Efficiency & Super Quiet - Duplex V units

Size		40	46	52	60	70	80	90
Condenser								
Type		Fin and Tube	Fin and Tube	Fin and Tube	Fin and Tube	Fin and Tube	Fin and Tube	Fin and Tube
Tube diameter	(mm)	9.52	9.52	9.52	9.52	9.52	9.52	9.52
Number of Rows	#	3	3	3	3	3	3	3
Fins per Foot	(fpf)	192	192	192	192	192	192	192
Fan								
Quantity	#	4	4	4	4	6	6	6
Diameter	(mm)	762	762	762	762	762	762	762
Drive Type		Direct	Direct	Direct	Direct	Direct	Direct	Direct
Std Amb. Speeds per Circuit (4)		1xD + 1xS	1xD + 1xS	1xD + 1xS	1xD + 1xS	1xD + 2xS	1xD + 2xS	1xD + 2xS
Low Amb. Speeds per Circuit (Option) (4)		1xVFD + 1xS	1xVFD + 1xS	1xVFD + 1xS	1xVFD + 1xS	1xVFD + 2xS	1xVFD + 2xS	1xVFD + 2xS
Airflow per Fan	(m ³ /h)	12073	12085	14444	14453	12032	13766	13777
Static Pressure	(Pa)	0	0	0	0	0	0	0
Power per Motor	(kW)	1.1	1.1	1.2	1.2	1.1	1.2	1.2
Rated Amps per Motor	(A)	3.12	3.12	3.12	3.12	3.12	3.12	3.12
Motor RPM	(rpm)	700	700	700	700	700	700	700
PHR								
Heat-Exchanger Type		Brazed Plates	Brazed Plates	Brazed Plates	Brazed Plates	Brazed Plates	Brazed Plates	Brazed Plates
Victaulic Connection	(mm)	38	38	38	38	38	38	38
Water Storage Capacity	(L)	0.0671*2	0.0671*2	0.0671*2	0.0915*2	0.0915*2	0.1098*2	0.122*2
Unit Water Connection								
Chilled Water	(mm)	65	65	65	80	80	80	80
Type (Standard)		Grooved	Grooved	Grooved	Grooved	Grooved	Grooved	Grooved
Dimensions								
Unit Length with Buffer Tank	(mm)	3416	3416	3416	3416	4330	4330	4330
Unit Length with VFD	(mm)	3193	3193	3193	3193	4107	4107	4107
Unit Length with Buffer Tank and VFD	(mm)	3704	3704	3704	3704	4618	4618	4618
Unit Length without Buffer Tank or VFD	(mm)	2905	2905	2905	2905	3819	3819	3819
Unit Width	(mm)	2266	2266	2266	2266	2266	2266	2266
Unit Height	(mm)	2150	2150	2150	2150	2150	2150	2150
Weight (Aluminium Fins without louver or VFD)								
Shipping Weight (5)	(kg)	1652	1679	1728	1910	2171	2220	2327
Operating Weight (5)	(kg)	1665	1697	1746	1928	2196	2247	2358
Additional weight (dual pump high head)	(kg)	226	225	226	316	319	319	319
Additional weight (dual pump standard head)	(kg)	209	221	221	221	237	237	237
Additional weight (single pump high head)	(kg)	179	178	179	220	222	222	222
Additional weight (single pump standard head)	(kg)	171	177	177	177	186	186	186
Additional weight (Buffer tank)	(kg)	189	188	188	188	189	189	189
Louver Weight	(kg)	32	32	32	32	37	37	37
Min. Starting/Oper. Ambient								
Std Unit	(°C)	7	7	7	7	7	7	7
Low Ambient (Option)	(°C)	-18	-18	-18	-18	-18	-18	-18
Refrigerant and Oil charge per circuit								
Refrigerant charge	(Kg)	19.1	19.1	22.7	22.7	29.9	33.6	33.6
Oil Charge	(L)	13.4	6.6	6.6	13.4	13.4	13.4	13.4

(1) Eurovent Cooling Mode Conditions (Evap. 12°C/7°C - Air. 35°C); Eurovent Heating Mode Condition (Evap. 40°C/45°C-Air. DB/WB 7°C/6°C)

(2) Rated Condition without Pump Package

(3) Single Pump Option

(4) S: Single Speed, D: Two Speed, VFD: Inverter.

(5) Base unit



General Data

Table 6. General Data - CXAM Standard Efficiency & Super Quiet - Duplex W units

Size		100	110	120	140	150	160	170
Eurovent Performances (1)								
Net Cooling Capacity	(kW)	272.2	289.5	317.0	370.6	391.7	426.2	443.0
Total Power Input in Cooling	(kW)	95.3	105.3	114.6	139.5	152.5	156.5	166.7
EER		2.9	2.7	2.8	2.7	2.6	2.7	2.7
Net Heating Capacity	(kW)	267.8	282.9	300.5	351.2	366.1	416.0	431.2
Total Power Input in Heating	(kW)	92.3	99.8	109.1	130.6	138.7	150.0	157.7
Heating COP		2.9	2.8	2.8	2.7	2.6	2.8	2.7
Main Power Supply		400/3/50	400/3/50	400/3/50	400/3/50	400/3/50	400/3/50	400/3/50
Sound Power Level	(dBA)	87	87	89	89	89	90	90
System Data								
Refrigerant Circuit	#	2	2	2	2	2	2	2
Capacity Steps	%	25-50-75-100	23-45-73-100	25-50-75-100	14-29-46-64-82-100	17-33-50-67-83-100	16-31-47-63-81-100	15-29-47-65-82-100
Units Amps								
Nominal Amps (2)	(A)	204	224	251	290	310	336	356
Start-up Amps (2)								
Standard Unit	(A)	418	488	514	503	523	599	619
With Soft Starter Option	(A)	314	360	386	399	419	471	491
Short Circuit Unit Capacity	(kA)	15	15	15	15	15	15	15
Max Supply Cable Size	(mm ²)	240	240	240	2 x 300	2 x 300	2 x 300	2 x 300
Compressor								
Compressor Number per Circuit	#	2	2	2	3	3	3	3
Type		Scroll	Scroll	Scroll	Scroll	Scroll	Scroll	Scroll
Model		CSHN315 & CSHN315	CSHN315 & CSHN374	CSHN374 & CSHN374	CSHN250 & CSHN315 & CSHN315	CSHN315 & CSHN315 & CSHN315	CSHN315 & CSHN315 & CSHN374	CSHN315 & CSHN374 & CSHN374
Rated Amps per Circuit	(A)	46.4 & 46.4	46.4 & 56.4	56.4 & 56.4	36.4 & 46.4 & 46.4	46.4 & 46.4 & 46.4	46.4 & 46.4 & 56.4	46.4 & 56.4 & 56.4
Locked Rotor Amps per Circuit	(A)	260 & 260	260 & 320	320 & 320	215 & 260 & 260	260 & 260 & 260	320 & 320 & 320	260 & 320 & 320
Motor RPM	(rpm)	2900	2900	2900	2900	2900	2900	2900
Sump heater per circuit	kW	160&160	160&160	160&160	160&160	160&160	160&160	160&160
Power Factor	#	0.85	0.85	0.85	0.85	0.85	0.85	0.85
Evaporator								
Quantity	#	1	1	1	1	1	1	1
Type		BPHE	BPHE	BPHE	BPHE	BPHE	BPHE	BPHE
Water Volume/Storage (Total)	(L)	32.4	32.4	39.2	40.8	46.7	46.7	46.7
Heater Power	(W)	400	400	500	500	500	500	500
Min. Flow	(L/Sec)	6.3	6.7	7.3	8.6	9.1	9.9	10.3
Max. Flow	(L/Sec)	18.9	20.0	22.0	25.7	27.2	29.6	30.8
Pump Package (Option Standard Head)								
Evaporator Head Pressure Available Single Pump	(kPa)	123.2	124.8	124.4	149.5	137.2	117.3	106.9
Evaporator Head Pressure Available Dual Pump	(kPa)	123.2	124.8	124.4	149.5	137.2	117.3	106.9
Power (3)	(kW)	5.5	7.5	7.5	11	11	11	11
Rated Amps (3)	(A)	10.6	13.8	13.8	19.6	19.6	19.6	19.6
Pump Package (Option High Head)								
Evaporator Head Pressure Available Single Pump	(kPa)	205.9	194.4	232.1	207.5	194.8	230.4	219.8
Evaporator Head Pressure Available Dual Pump	(kPa)	205.9	194.4	232.1	207.5	194.8	230.4	219.8
Power (3)	(kW)	7.5	7.5	11	11	11	15	15
Rated Amps (3)	(A)	13.8	13.8	19.6	19.6	19.6	26.5	26.5
Hydraulic Module components								
Expansion Tank Volume	(L)	60	60	60	60	60	60	60
User Volume Expansion Capacity	(L)	900	900	900	900	900	900	900
Max. Water-side Operating Pressure without Hydraulic Module	(kPa)	1000	1000	1000	1000	1000	1000	1000
Max. Water-side Operating Pressure with Hydraulic Module	(kPa)	500	500	500	500	500	500	500
Antifreeze Heater without pump package and without strainer	(W)	120	120	120	240	240	240	240
Antifreeze Heater without pump package and with strainer	(W)	240	240	240	300	300	300	300
Pump package antifreeze Heater	(W)	980	980	980	1100	1100	1100	1100
Buffer tank antifreeze Heater	(W)	1200	1200	1200	1200	1200	1200	1200

Table 6. General Data - CXAM Standard Efficiency & Super Quiet - Duplex W units

Size		100	110	120	140	150	160	170
VFD Weight	(kg)	21	21	21	21	21	21	21
Water tank Volume	(L)	725	725	725	725	725	725	725
Condenser								
Type		Fin and Tube	Fin and Tube	Fin and Tube	Fin and Tube	Fin and Tube	Fin and Tube	Fin and Tube
Tube diameter	(mm)	9.52	9.52	9.52	9.52	9.52	9.52	9.52
Number of Rows	#	3	3	3	3	3	3	3
Fins per Foot	(fpf)	192	192	192	192	192	192	192
Fan								
Quantity	#	6	6	8	10	10	12	12
Diameter	(mm)	762	762	762	762	762	762	762
Drive Type		Direct	Direct	Direct	Direct	Direct	Direct	Direct
Std Amb. Speeds per Circuit (4)		1xD + 2xS	1xD + 2xS	4xS	5xS	5xS	6xS	6xS
Low Amb. Speeds per Circuit (Option) (4)		1xVFD + 2xS	1xVFD + 2xS	1xVFD + 3xS	1xVFD + 4xS	1xVFD + 4xS	1xVFD + 5xS	1xVFD + 5xS
Airflow per Fan	(m ³ /h)	16237	16241	14249	14244	14250	14240	14244
Static Pressure	(Pa)	0	0	0	0	0	0	0
Power per Motor	(kW)	1.1	1.1	1.2	1.2	1.2	1.2	1.2
Rated Amps per Motor	(A)	3.12	3.12	3.12	3.12	3.12	3.12	3.12
Motor RPM	(rpm)	700	700	700	700	700	700	700
PHR								
Heat-Exchanger Type		Brazed Plates	Brazed Plates	Brazed Plates	Brazed Plates	Brazed Plates	Brazed Plates	Brazed Plates
Victaulic Connection	(mm)	64	64	64	64	64	64	64
Water Storage Capacity	(L)	0.122*2	0.1647*2	0.1647*2	0.2135*2	0.2135*2	0.2135*2	0.2135*2
Unit Water Connection								
Chilled Water	(mm)	100	100	100	100	100	100	100
Type (Standard)		Grooved	Grooved	Grooved	Grooved	Grooved	Grooved	Grooved
Dimensions								
Unit Length with Buffer Tank	(mm)	4230	4230	4230	5145	5145	6062	6062
Unit Length with VFD	(mm)	4558	4558	4558	5473	5473	6388	6388
Unit Length with Buffer Tank and VFD	(mm)	4558	4558	4558	5473	5473	6388	6388
Unit Length without Buffer Tank or VFD	(mm)	4230	4230	4230	5145	5145	6062	6062
Unit Width	(mm)	2273	2273	2273	2273	2273	2273	2273
Unit Height	(mm)	2344	2344	2344	2344	2344	2344	2344
Weight (Aluminium Fins without louver or VFD)								
Shipping Weight (5)	(kg)	2773	2773	2884	3457	3570	3956	3956
Operating Weight (5)	(kg)	2808	2808	2925	3500	3618	4005	4005
Additional weight (dual pump high head)	(kg)	406	406	488	511	510	583	583
Additional weight (dual pump standard head)	(kg)	325	405	405	510	510	556	556
Additional weight (single pump high head)	(kg)	310	310	355	377	377	436	436
Additional weight (single pump standard head)	(kg)	274	314	314	377	376	423	423
Additional weight (Buffer tank)	(kg)	188	188	188	188	188	188	188
Louver Weight	(kg)	47	47	47	51	51	56	56
Min. Starting/Oper. Ambient								
Std Unit	(°C)	7	7	7	7	7	7	7
Low Ambient (Option)	(°C)	-18	-18	-18	-18	-18	-18	-18
Refrigerant and Oil charge per circuit								
Refrigerant charge	(Kg)	46.3	46.3	47.2	57.2	57.2	66.2	67.1
Oil Charge	(L)	13.4	13.9	14.4	22.5	23	23.5	24

(1) Eurovent Cooling Mode Conditions (Evap. 12°C/7°C - Air. 35°C); Eurovent Heating Mode Condition (Evap. 40°C/45°C-Air. DB/WB 7°C/6°C)

(2) Rated Condition without Pump Package

(3) Single Pump Option

(4) S: Single Speed, D: Two Speed, VFD: Inverter.

(5) Base unit



General Data

Table 7. General Data - CXAM Standard Efficiency & Comprehensive Acoustic Package - Simplex units

Size		20	23	26	30	35	39
Eurovent Performances (1)							
Net Cooling Capacity	(kW)	53.0	59.3	68.6	76.1	89.7	102.4
Total Power Input in Cooling	(kW)	18.5	21.1	25.1	28.1	32.5	39.5
EER		2.9	2.8	2.7	2.7	2.8	2.6
Heating net Capacity	(kW)	60.0	67.7	75.3	84.9	97.2	108.1
Total Power Input in Heating	(kW)	18.0	20.5	22.5	27.0	30.9	34.7
Heating COP		3.3	3.3	3.3	3.1	3.1	3.1
Main Power Supply		400/3/50	400/3/50	400/3/50	400/3/50	400/3/50	400/3/50
Sound Power Level	(dBA)	77	77	77	79	82	84
System Data							
Refrigerant Circuit	#	1	1	1	1	1	1
Capacity Steps	%	50-100	43-100	50-100	50-100	43-100	50-100
Units Amps							
Nominal Amps (2)	(A)	47	51	55	60	71	81
Start-up Amps (2)							
Standard Unit	(A)	168	184	188	194	249	260
With Soft Starter Option	(A)	111	121	125	130	163	174
Short Circuit Unit Capacity	(kA)	15	15	15	15	15	15
Max Supply Cable Size	(mm2)	95	95	95	95	150	150
Compressor							
Compressor Number per Circuit	#	2	2	2	2	2	2
Type		Scroll	Scroll	Scroll	Scroll	Scroll	Scroll
Model		CSHD125 & CSHD125	CSHD125 & CSHD161	CSHD161 & CSHD161	CSHN184 & CSHN184	CSHN184 & CSHN250	CSHN250 & CSHN250
Rated Amps per Circuit	(A)	20.7 & 20.7	20.7 & 25	25 & 25	26 & 26	26 & 36.4	36.4 & 36.4
Locked Rotor Amps per Circuit	(A)	142 & 142	142 & 158	158 & 158	160 & 160	160 & 215	215 & 215
Motor RPM	(rpm)	2900	2900	2900	2900	2900	2900
Sump heater per circuit	kW	90&90	90&90	90&90	160&160	160&160	160&160
Power Factor	#	0.85	0.85	0.85	0.85	0.85	0.85
Evaporator							
Quantity	#	1	1	1	1	1	1
Type		BPHE	BPHE	BPHE	BPHE	BPHE	BPHE
Water Volume/Storage (Total)	(L)	4.0	4.0	6.7	6.3	8.2	10.6
Heater Power	(W)	200	200	200	200	300	300
Min. Flow	(L/Sec)	1.2	1.4	1.6	1.8	2.1	2.4
Max. Flow	(L/Sec)	3.7	4.1	4.8	5.3	6.3	7.1
Pump Package (Option Standard Head)							
Evaporator Head Pressure Available Single Pump	(kPa)	96.2	68.8	80.2	77.5	75.9	111.9
Evaporator Head Pressure Available Dual Pump	(kPa)	96.2	68.8	80.2	77.5	75.9	111.9
Power (3)	(kW)	1.5	1.5	1.5	1.5	1.5	3
Rated Amps (3)	(A)	3.25	3.25	3.25	3.25	3.25	6.1
Pump Package (Option High Head)							
Evaporator Head Pressure Available Single Pump	(kPa)	273.1	245.3	254.7	249.7	243.3	237.7
Evaporator Head Pressure Available Dual Pump	(kPa)	273.1	245.3	254.7	249.7	243.3	237.7
Power (3)	(kW)	4	4	4	4	5.5	5.5
Rated Amps (3)	(A)	7.59	7.59	7.59	7.59	10.6	10.6
Hydraulic Module components							
Water strainer Ø	(mm)	50	50	50	65	65	65
Expansion Tank Volume	(L)	25	25	25	25	25	25
User Volume Expansion Capacity	(L)	50	50	50	50	50	50
Max. Water-side Operating Pressure without Hydraulic Module	(kPa)	1000	1000	1000	1000	1000	1000
Max. Water-side Operating Pressure with Hydraulic Module	(kPa)	500	500	500	500	500	500
Antifreeze Heater without pump package and without strainer	(W)				120		
Antifreeze Heater without pump package and with strainer					180		
Pump package antifreeze Heater	(W)				530		
Buffer tank antifreeze Heater	(W)				800		
VFD Weight	(kg)	10	10	10	10	10	10
Water tank Volume	(L)	506	506	506	506	506	506
Condenser							
Type		Fin and Tube	Fin and Tube	Fin and Tube	Fin and Tube	Fin and Tube	Fin and Tube

Table 7. General Data - CXAM Standard Efficiency & Comprehensive Acoustic Package - Simplex units

Size		20	23	26	30	35	39
Tube diameter	(mm)	9.52	9.52	9.52	9.52	9.52	9.52
Number of Rows	#	3	3	3	3	3	3
Fins per Foot	(fpf)	192	192	192	192	192	192
Fan							
Quantity	#	2	2	2	3	3	3
Diameter	(mm)	757	757	757	757	757	757
Drive Type		Direct	Direct	Direct	Direct	Direct	Direct
Std Amb. Speeds per Circuit (4)		1xD + 1xS	1xD + 1xS	1xD + 1xS	1xD + 2xS	1xD + 2xS	1xD + 2xS
Low Amb. Speeds per Circuit (Option) (4)		1xVFD + 1xS	1xVFD + 1xS	1xVFD + 1xS	1xVFD + 2xS	1xVFD + 2xS	1xVFD + 2xS
Airflow per Fan	(m3/h)	9222	9847	9851	8568	9661	9665
Static Pressure	(Pa)	0	0	0	0	0	0
Power per Motor	(kW)	0.4	0.4	0.4	0.4	0.4	0.4
Rated Amps per Motor	(A)	1.35	1.35	1.35	1.35	1.35	1.35
Motor RPM	(rpm)	700	700	700	700	700	700
PHR							
Heat-Exchanger Type		Brazed Plates	Brazed Plates	Brazed Plates	Brazed Plates	Brazed Plates	Brazed Plates
Victaulic Connection	(mm)	38	38	38	38	38	38
Water Storage Capacity	(L)	0.0671	0.0671	0.0671	0.0915	0.0915	0.1098
Unit Water Connection							
Chilled Water	(mm)	50	50	50	65	65	65
Type (Standard)		Grooved	Grooved	Grooved	Grooved	Grooved	Grooved
Dimensions							
Unit Length with Buffer Tank	(mm)	3418	3418	3418	4332	4332	4332
Unit Length with VFD	(mm)	2908	2908	2908	3822	3822	3822
Unit Length with Buffer Tank and VFD	(mm)	3418	3418	3418	4332	4332	4332
Unit Length without Buffer Tank or VFD	(mm)	2908	2908	2908	3822	3822	3822
Unit Width	(mm)	1301	1301	1301	1301	1301	1301
Unit Height	(mm)	2153	2153	2153	2153	2153	2153
Weight (Aluminium Fins without louver or VFD)							
Shipping Weight (5)	(kg)	944	968	981	1257	1305	1313
Operating Weight (5)	(kg)	951	976	992	1267	1317	1328
Additional weight (dual pump high head)	(kg)	199	200	200	241	255	256
Additional weight (dual pump standard head)	(kg)	183	183	183	225	225	232
Additional weight (single pump high head)	(kg)	162	163	163	204	208	209
Additional weight (single pump standard head)	(kg)	153	154	154	195	195	199
Additional weight (Buffer tank)	(kg)	188	188	188	189	189	188
Louver Weight	(kg)	19	19	19	25	25	25
Min. Starting/Oper. Ambient							
Std Unit	(°C)	7	7	7	7	7	7
Low Ambient (Option)	(°C)	-18	-18	-18	-18	-18	-18
Refrigerant and Oil charge per circuit							
Refrigerant charge	(Kg)	20	22.7	22.7	26.3	34.5	34.5
Oil Charge	(L)	6.6	6.6	6.6	13.4	13.4	13.4

(1) Eurovent Cooling Mode Conditions (Evap. 12°C/7°C - Air. 35°C); Eurovent Heating Mode Condition (Evap. 40°C/45°C-Air. DB/WB 7°C/6°C)

(2) Rated Condition without Pump Package

(3) Single Pump Option

(4) S: Single Speed, D: Two Speed, VFD: Inverter.

(5) Base unit



General Data

Table 8. General Data - CXAM Standard Efficiency & Comprehensive Acoustic Package - Duplex V units

Size		40	46	52	60	70	80
Eurovent Performances (1)							
Net Cooling Capacity	(kW)	106.6	119.0	134.5	154.4	180.3	207.8
Total Power Input in Cooling	(kW)	37.0	44.0	49.8	56.3	67.2	79.3
EER		2.9	2.7	2.7	2.7	2.7	2.6
Heating net Capacity	(kW)	121.7	136.3	153.1	171.6	195.8	218.4
Total Power Input in Heating	(kW)	36.4	40.4	45.4	54.1	61.8	69.8
Heating COP		3.3	3.4	3.4	3.2	3.2	3.1
Main Power Supply		400/3/50	400/3/50	400/3/50	400/3/50	400/3/50	400/3/50
Sound Power Level	(dBA)	80	80	80	82	85	87
System Data							
Refrigerant Circuit	#	2	2	2	2	2	2
Capacity Steps	%	25-50-75-100	21-43-71-100	25-50-75-100	25-50-75-100	21-43-71-100	25-50-75-100
Units Amps							
Nominal Amps (2)	(A)	88	97	105	112	133	154
Start-up Amps (2)							
Standard Unit	(A)	210	230	238	246	312	332
With Soft Starter Option	(A)	153	167	175	182	226	246
Short Circuit Unit Capacity	(kA)	15	15	15	15	15	15
Max Supply Cable Size	(mm ²)	150	150	150	240	240	240
Compressor							
Compressor Number per Circuit	#	2	2	2	2	2	2
Type		Scroll	Scroll	Scroll	Scroll	Scroll	Scroll
Model		CSHD125 & CSHD125	CSHD125 & CSHD161	CSHD161 & CSHD161	CSHN184 & CSHN184	CSHN184 & CSHN250	CSHN250 & CSHN250
Rated Amps per Circuit	(A)	20.7 & 20.7	20.7 & 25	25 & 25	26 & 26	26 & 36.4	36.4 & 36.4
Locked Rotor Amps per Circuit	(A)	142 & 142	142 & 158	158 & 158	160 & 160	160 & 215	215 & 215
Motor RPM	(rpm)	2900	2900	2900	2900	2900	2900
Sump heater per circuit	kW	160&160	160&160	160&160	160&160	160&160	160&160
Power Factor	#	0.85	0.85	0.85	0.85	0.85	0.85
Evaporator							
Quantity	#	1	1	1	1	1	1
Type		BPHE	BPHE	BPHE	BPHE	BPHE	BPHE
Water Volume/Storage (Total)	(L)	9.1	14.3	14.3	15.6	21.5	24.0
Heater Power	(W)	200	300	300	300	400	400
Min. Flow	(L/Sec)	2.4	2.7	3.1	3.6	4.2	4.8
Max. Flow	(L/Sec)	7.3	8.1	9.3	10.7	12.5	14.4
Pump Package (Option Standard Head)							
Evaporator Head Pressure Available Single Pump	(kPa)	75.5	108.9	88.0	105.9	135.8	119.1
Evaporator Head Pressure Available Dual Pump	(kPa)	75.5	108.9	88.0	105.9	135.8	119.1
Power (3)	(kW)	3	4	4	4	5.5	5.5
Rated Amps (3)	(A)	6.1	7.59	7.59	7.59	10.6	10.6
Pump Package (Option High Head)							
Evaporator Head Pressure Available Single Pump	(kPa)	230.3	231.1	203.1	216.0	211.9	196.3
Evaporator Head Pressure Available Dual Pump	(kPa)	230.3	231.1	203.1	216.0	211.9	196.3
Power (3)	(kW)	5.5	5.5	5.5	7.5	7.5	7.5
Rated Amps (3)	(A)	10.6	10.6	10.6	13.8	13.8	13.8
Hydraulic Module components							
Water strainer Ø	(mm)	65	65	65	80	80	80
Expansion Tank Volume	(L)	25	25	25	25	25	25
User Volume Expansion Capacity	(L)	50	50	50	50	50	50
Max. Water-side Operating Pressure without Hydraulic Module	(kPa)	1000	1000	1000	1000	1000	1000
Max. Water-side Operating Pressure with Hydraulic Module	(kPa)	500	500	500	500	500	500
Antifreeze Heater without pump package and without strainer	(W)				120		
Antifreeze Heater without pump package and with strainer	(W)				120		
Pump package antifreeze Heater	(W)				860		
Buffer tank antifreeze Heater	(W)				800		
VFD Weight	(kg)	15	15	15	15	15	15
Water tank Volume	(L)	500	500	500	500	500	500
Condenser							
Type		Fin and Tube	Fin and Tube	Fin and Tube	Fin and Tube	Fin and Tube	Fin and Tube

Table 8. General Data - CXAM Standard Efficiency & Comprehensive Acoustic Package - Duplex V units

Size		40	46	52	60	70	80
Tube diameter	(mm)	9.52	9.52	9.52	9.52	9.52	9.52
Number of Rows	#	3	3	3	3	3	3
Fins per Foot	(fpf)	192	192	192	192	192	192
Fan							
Quantity	#	4	4	4	6	6	6
Diameter	(mm)	757	757	757	757	757	757
Drive Type		Direct	Direct	Direct	Direct	Direct	Direct
Std Amb. Speeds per Circuit (4)		1xD + 1xS	1xD + 1xS	1xD + 1xS	1xD + 2xS	1xD + 2xS	1xD + 2xS
Low Amb. Speeds per Circuit (Option) (4)		1xVFD + 1xS	1xVFD + 1xS	1xVFD + 1xS	1xVFD + 2xS	1xVFD + 2xS	1xVFD + 2xS
Airflow per Fan	(m3/h)	9222	9225	9850	8568	9211	9666
Static Pressure	(Pa)	0	0	0	0	0	0
Power per Motor	(kW)	0.4	0.4	0.4	0.4	0.4	0.4
Rated Amps per Motor	(A)	1.35	1.35	1.35	1.35	1.35	1.35
Motor RPM	(rpm)	700	700	700	700	700	700
PHR							
Heat-Exchanger Type		Brazed Plates	Brazed Plates	Brazed Plates	Brazed Plates	Brazed Plates	Brazed Plates
Victaulic Connection	(mm)	38	38	38	38	38	38
Water Storage Capacity	(L)	0.0671*2	0.0671*2	0.0671*2	0.0915*2	0.0915*2	0.1098*2
Unit Water Connection							
Chilled Water	(mm)	65	65	65	80	80	80
Type (Standard)		Grooved	Grooved	Grooved	Grooved	Grooved	Grooved
Dimensions							
Unit Length with Buffer Tank	(mm)	3416	3416	3416	4330	4330	4330
Unit Length with VFD	(mm)	3193	3193	3193	4107	4107	4107
Unit Length with Buffer Tank and VFD	(mm)	3704	3704	3704	4618	4618	4618
Unit Length without Buffer Tank or VFD	(mm)	2905	2905	2905	3819	3819	3819
Unit Width	(mm)	2266	2266	2266	2266	2266	2266
Unit Height	(mm)	2150	2150	2150	2150	2150	2150
Weight (Aluminium Fins without louver or VFD)							
Shipping Weight (5)	(kg)	1720	1747	1796	2202	2261	2310
Operating Weight (5)	(kg)	1733	1765	1814	2221	2286	2337
Additional weight (dual pump high head)	(kg)	226	225	226	319	319	319
Additional weight (dual pump standard head)	(kg)	209	221	221	223	237	237
Additional weight (single pump high head)	(kg)	179	178	179	222	222	222
Additional weight (single pump standard head)	(kg)	171	177	177	179	186	186
Additional weight (Buffer tank)	(kg)	189	188	188	188	189	189
Louver Weight	(kg)	32	32	32	37	37	37
Min. Starting/Oper. Ambient							
Std Unit	(°C)	7	7	7	7	7	7
Low Ambient (Option)	(°C)	-18	-18	-18	-18	-18	-18
Refrigerant and Oil charge per circuit							
Refrigerant charge	(Kg)	20	22.7	22.7	26.3	29	31.8
Oil Charge	(L)	6.6	6.6	6.6	13.4	13.4	13.4

(1) Eurovent Cooling Mode Conditions (Evap. 12°C/7°C - Air. 35°C); Eurovent Heating Mode Condition (Evap. 40°C/45°C-Air. DB/WB 7°C/6°C)

(2) Rated Condition without Pump Package

(3) Single Pump Option

(4) S: Single Speed, D: Two Speed, VFD: Inverter.

(5) Base unit



General Data

Table 9. General Data - CXAM Standard Efficiency & Comprehensive Acoustic Package - Duplex W units

Size		90	100	110	120	140	150	160
Eurovent Performances (1)								
Net Cooling Capacity	(kW)	239.3	263.6	283.9	308.5	363.2	392.3	407.0
Total Power Input in Cooling	(kW)	83.3	96.5	105.4	112.0	136.9	151.0	163.0
EER		2.9	2.7	2.7	2.8	2.7	2.6	2.5
Heating net Capacity	(kW)	244.1	262.7	278.9	296.3	352.3	388.0	402.3
Total Power Input in Heating	(kW)	79.8	87.9	95.1	104.0	123.0	131.7	139.4
Heating COP		3.1	3.0	2.9	2.8	2.9	2.9	2.9
Main Power Supply		400/3/50	400/3/50	400/3/50	400/3/50	400/3/50	400/3/50	400/3/50
Sound Power Level	(dBA)	85	83	83	85	86	84	85
System Data								
Refrigerant Circuit	#	2	2	2	2	2	2	2
Capacity Steps	%	22-44-72-100	25-50-75-100	23-45-73-100	25-50-75-100	14-29-46-64-82-100	17-33-50-67-83-100	16-31-47-63-81-100
Units Amps								
Nominal Amps (2)	(A)	176	196	216	239	275	295	315
Start-up Amps (2)								
Standard Unit	(A)	390	410	480	503	488	508	578
With Soft Starter Option	(A)	286	306	352	375	384	404	450
Short Circuit Unit Capacity	(kA)	15	15	15	15	15	15	15
Max Supply Cable Size	(mm ²)	240	240	240	240	2 x 300	2 x 300	2 x 300
Compressor								
Compressor Number per Circuit	#	2	2	2	2	3	3	3
Type		Scroll	Scroll	Scroll	Scroll	Scroll	Scroll	Scroll
Model		CSHN250 & CSHN315	CSHN315 & CSHN315	CSHN315 & CSHN374	CSHN374 & CSHN374	CSHN250 & CSHN315 & CSHN315	CSHN315 & CSHN315 & CSHN315	CSHN315 & CSHN315 & CSHN315
Rated Amps per Circuit	(A)	36.4 & 46.4	46.4 & 46.4	46.4 & 56.4	56.4 & 56.4	36.4 & 46.4 & 46.4	46.4 & 46.4 & 46.4	46.4 & 46.4 & 56.4
Locked Rotor Amps per Circuit	(A)	215 & 260	260 & 260	260 & 320	320 & 320	215 & 260 & 260	260 & 260 & 260	320 & 320 & 320
Motor RPM	(rpm)	2900	2900	2900	2900	2900	2900	2900
Sump heater per circuit	kW	160&160	160&160	160&160	160&160	160&160	160&160	160&160
Power Factor	#	0.85	0.85	0.85	0.85	0.85	0.85	0.85
Evaporator								
Quantity	#	1	1	1	1	1	1	1
Type		BPHE	BPHE	BPHE	BPHE	BPHE	BPHE	BPHE
Water Volume/Storage (Total)	(L)	24.0	32.4	32.4	32.4	39.2	46.7	46.7
Heater Power	(W)	400	400	400	400	500	500	500
Min. Flow	(L/Sec)	5.5	6.1	6.6	7.1	8.4	9.1	9.4
Max. Flow	(L/Sec)	16.6	18.2	19.7	21.4	25.2	27.2	28.2
Pump Package (Option Standard Head)								
Evaporator Head Pressure Available Single Pump	(kPa)	133.1	130.5	127.0	115.7	150.8	137.0	128.6
Evaporator Head Pressure Available Dual Pump	(kPa)	133.1	130.5	127.0	115.7	150.8	137.0	128.6
Power (3)	(kW)	5.5	5.5	7.5	7.5	11	11	11
Rated Amps (3)	(A)	10.6	10.6	13.8	13.8	19.6	19.6	19.6
Pump Package (Option High Head)								
Evaporator Head Pressure Available Single Pump	(kPa)	209.3	211.6	197.8	223.8	208.9	194.7	241.9
Evaporator Head Pressure Available Dual Pump	(kPa)	209.3	211.6	197.8	223.8	208.9	194.7	241.9
Power (3)	(kW)	7.5	7.5	7.5	11	11	11	15
Rated Amps (3)	(A)	13.8	13.8	13.8	19.6	19.6	19.6	26.5
Hydraulic Module components								
Water strainer Ø	(mm)	100	100	100	100	100	100	100
Expansion Tank Volume	(L)	60	60	60	60	60	60	60
User Volume Expansion Capacity	(L)	900	900	900	900	900	900	900
Max. Water-side Operating Pressure without Hydraulic Module	(kPa)	1000	1000	1000	1000	1000	1000	1000
Max. Water-side Operating Pressure with Hydraulic Module	(kPa)	500	500	500	500	500	500	500
Antifreeze Heater without pump package and without strainer	(W)	120	120	120	240	240	240	240
Antifreeze Heater without pump package and with strainer	(W)	240	240	240	300	300	300	300
Pump package antifreeze Heater	(W)	980	980	980	1100	1100	1100	1100

Table 9. General Data - CXAM Standard Efficiency & Comprehensive Acoustic Package - Duplex W units

Size		90	100	110	120	140	150	160
Buffer tank antifreeze Heater	(W)	1200	1200	1200	1200	1200	1200	1200
VFD Weight	(kg)	21	21	21	21	21	21	21
Water tank Volume	(L)	725	725	725	725	725	725	725
Condenser								
Type		Fin and Tube	Fin and Tube	Fin and Tube	Fin and Tube	Fin and Tube	Fin and Tube	Fin and Tube
Tube diameter	(mm)	9.52	9.52	9.52	9.52	9.52	9.52	9.52
Number of Rows	#	3	3	3	3	3	3	3
Fins per Foot	(fpf)	192	192	192	192	192	192	192
Fan								
Quantity	#	8	8	8	10	12	12	12
Diameter	(mm)	757	757	757	757	757	757	757
Drive Type		Direct	Direct	Direct	Direct	Direct	Direct	Direct
Std Amb. Speeds per Circuit (4)		4xS	4xS	4xS	5xS	6xS	6xS	6xS
Low Amb. Speeds per Circuit (Option) (4)		1xVFD + 3xS	1xVFD + 3xS	1xVFD + 3xS	1xVFD + 4xS	1xVFD + 5xS	1xVFD + 5xS	1xVFD + 5xS
Airflow per Fan	(m3/h)	9809	9811	10304	9810	9809	9811	9813
Static Pressure	(Pa)	0	0	0	0	0	0	0
Power per Motor	(kW)	0.4	0.4	0.3	0.4	0.4	0.4	0.4
Rated Amps per Motor	(A)	1.35	1.35	1.35	1.35	1.35	1.35	1.35
Motor RPM	(rpm)	700	700	700	700	700	700	700
PHR								
Heat-Exchanger Type		Brazed Plates	Brazed Plates	Brazed Plates	Brazed Plates	Brazed Plates	Brazed Plates	Brazed Plates
Victaulic Connection	(mm)	64	64	64	64	64	64	64
Water Storage Capacity	(L)	0.122*2	0.122*2	0.1647*2	0.1647*2	0.2135*2	0.2135*2	0.2135*2
Unit Water Connection								
Chilled Water	(mm)	100	100	100	100	100	100	100
Type (Standard)		Grooved	Grooved	Grooved	Grooved	Grooved	Grooved	Grooved
Dimensions								
Unit Length with Buffer Tank	(mm)	4230	4230	5145	5145	6062	6062	6062
Unit Length with VFD	(mm)	4558	4558	5473	5473	6388	6388	6388
Unit Length with Buffer Tank and VFD	(mm)	4558	4558	5473	5473	6388	6388	6388
Unit Length without Buffer Tank or VFD	(mm)	4230	4230	5145	5145	6062	6062	6062
Unit Width	(mm)	2273	2273	2273	2273	2273	2273	2273
Unit Height	(mm)	2344	2344	2344	2344	2344	2344	2344
Weight (Aluminium Fins without louver or VFD)								
Shipping Weight (5)	(kg)	2857	2977	3231	3321	3993	4110	4110
Operating Weight (5)	(kg)	2884	3012	3266	3356	4034	4159	4159
Additional weight (dual pump high head)	(kg)	406	406	428	510	556	557	583
Additional weight (dual pump standard head)	(kg)	325	325	427	427	556	556	556
Additional weight (single pump high head)	(kg)	310	310	332	377	423	423	436
Additional weight (single pump standard head)	(kg)	274	274	336	336	422	423	423
Additional weight (Buffer tank)	(kg)	188	188	188	188	189	188	188
Louver Weight	(kg)	47	47	51	51	56	56	56
Min. Starting/Oper. Ambient								
Std Unit	(°C)	7	7	7	7	7	7	7
Low Ambient (Option)	(°C)	-18	-18	-18	-18	-18	-18	-18
Refrigerant and Oil charge per circuit								
Refrigerant charge	(Kg)	46.3	46.3	57.2	57.2	68.9	68.9	68
Oil Charge	(L)	13.4	13.4	13.9	14.4	22.5	23	23.5

- (1) Eurovent Cooling Mode Conditions (Evap. 12°C/7°C - Air. 35°C); Eurovent Heating Mode Condition (Evap. 40°C/45°C-Air. DB/WB 7°C/6°C)
(2) Rated Condition without Pump Package
(3) Single Pump Option
(4) S: Single Speed, D: Two Speed, VFD: Inverter.
(5) Base unit



General Data

Table 10. General Data - CXAM High Efficiency & Compact - Simplex units

Size		20	23	26	30	35
Eurovent Performances (1)						
Net Cooling Capacity	(kW)	57.9	64.3	75.3	80.4	94.2
Total Power Input in Cooling	(kW)	18.2	20.8	23.6	26.6	31.7
EER		3.2	3.1	3.2	3.0	3.0
Net Heating Capacity	(kW)	62.4	69.6	77.8	87.9	99.6
Total Power Input in Heating	(kW)	18.6	21.0	24.5	28.4	32.0
Heating COP		3.4	3.3	3.2	3.1	3.1
Main Power Supply		400/3/50	400/3/50	400/3/50	400/3/50	400/3/50
Sound Power Level	(dBA)	85	85	87	88	90
System Data						
Refrigerant Circuit	#	1	1	1	1	1
Capacity Steps	%	50-100	43-100	50-100	50-100	43-100
Units Amps						
Maximum Amps (2)	(A)	49	54	62	64	74
Start-up Amps (2)						
Standard Unit	(A)	171	187	195	198	253
With Soft Starter Option	(A)	114	124	132	134	167
Short Circuit Unit Capacity	(kA)	15	15	15	15	15
Max Supply Cable Size	(mm ²)	95	95	95	95	150
Compressor						
Compressor Number per Circuit	#	2	2	2	2	2
Type		Scroll	Scroll	Scroll	Scroll	Scroll
Model		CSHD125&CS HD125	CSHD125&CS HD161	CSHD161&CS HD161	CSHN184&CS HN184	CSHN184&CS HN250
Rated Amps per Circuit	(A)	20.7 & 20.7	20.7 & 25	25 & 25	26 & 26	26 & 36.4
Locked Rotor Amps per Circuit	(A)	142 & 142	142 & 158	158 & 158	160 & 160	160 & 215
Motor RPM	(rpm)	2900	2900	2900	2900	2900
Sump heater per circuit	kW	90&90	90&90	90&90	160&160	160&160
Power Factor	#	0.85	0.85	0.85	0.85	0.85
Evaporator						
Quantity	#	1	1	1	1	1
Type		BPHE	BPHE	BPHE	BPHE	BPHE
Water Volume/Storage (Total)	(L)	6.7	6.7	8.2	6.3	10.6
Antifreeze Heater	(W)	200	200	200	200	300
Min. Flow	(L/Sec)	1.3	1.5	1.7	1.9	2.2
Max. Flow	(L/Sec)	4.0	4.5	5.2	5.6	6.6
Pump Package (Option Standard Head)						
Evaporator Head Pressure Available Single Pump	(kPa)	112.9	86.7	76.2	68.2	83.2
Evaporator Head Pressure Available Dual Pump	(kPa)	112.9	86.7	76.2	68.2	83.2
Power (3)	(kW)	1.5	1.5	1.5	1.5	1.5
Rated Amps (3)	(A)	3.25	3.25	3.25	3.25	3.25
Pump Package (Option High Head)						
Evaporator Head Pressure Available Single Pump	(kPa)	289.5	262.2	248.8	238.5	249.3
Evaporator Head Pressure Available Dual Pump	(kPa)	289.5	262.2	248.8	238.5	249.3
Power (3)	(kW)	4	4	4	4	5.5
Rated Amps (3)	(A)	7.59	7.59	7.59	7.59	10.6
Hydraulic Module Components						
Expansion Tank Volume	(L)	25	25	25	25	25
User Volume Expansion Capacity	(L)	50	50	50	50	50
Max. Water-side Operating Pressure without Hydraulic Module	(kPa)	1000	1000	1000	1000	1000
Max. Water-side Operating Pressure with Hydraulic Module	(kPa)	500	500	500	500	500
Antifreeze Heater without pump package and without strainer	(W)			120		
Antifreeze Heater without pump package and with strainer	(W)			180		
Pump package antifreeze Heater	(W)			530		
Buffer tank antifreeze Heater	(W)			800		
VFD Weight	(kg)	10	10	10	10	10
Water tank Volume	(L)	506	506	506	506	506

Table 10. General Data - CXAM High Efficiency & Compact - Simplex units

Condenser						
Type		Fin and Tube	Fin and Tube	Fin and Tube	Fin and Tube	Fin and Tube
Tube diameter	(mm)	9.52	9.52	9.52	9.52	9.52
Number of Rows	#	3	3	3	3	3
Fins per Foot	(fpf)	192	192	192	192	192
Fan						
Quantity	#	2	2	3	3	3
Diameter	(mm)	757	757	757	757	757
Drive Type		Direct	Direct	Direct	Direct	Direct
Std Amb. Speeds per Circuit (4)		1xD + 1xS	1xD + 1xS	1xD + 2xS	1xD + 2xS	1xD + 2xS
Low Amb. Speeds per Circuit (Option) (4)		1xVFD + 1xS	1xVFD + 1xS	1xVFD + 2xS	1xVFD + 2xS	1xVFD + 2xS
Airflow per Fan	(m3/h)	13060	13062	12250	12823	12827
Static Pressure	(Pa)	0	0	0	0	0
Power per Motor	(kW)	0.8	0.8	0.9	0.8	0.8
Rated Amps per Motor	(A)	1.95	1.95	1.95	1.95	1.95
Motor RPM	(rpm)	920	920	920	920	920
PHR						
Heat-Exchanger Type		Brazed Plates	Brazed Plates	Brazed Plates	Brazed Plates	Brazed Plates
Victaulic Connection	(mm)	38	38	38	38	38
Water Storage Capacity	(L)	0.0671	0.0671	0.0671	0.0915	0.0915
Unit Water Connection						
Chilled Water	(mm)	50	50	65	65	65
Type (Standard)		Grooved	Grooved	Grooved	Grooved	Grooved
Dimensions						
Unit Length with Buffer Tank	(mm)	3418	3418	4332	4332	4332
Unit Length with VFD	(mm)	2908	2908	3822	3822	3822
Unit Length with Buffer Tank and VFD	(mm)	3418	3418	4332	4332	4332
Unit Length without Buffer Tank or VFD	(mm)	2908	2908	3822	3822	3822
Unit Width	(mm)	1301	1301	1301	1301	1301
Unit Height	(mm)	2153	2153	2153	2153	2153
Weight (Aluminium Fins without louver or VFD)						
Shipping Weight (5)	(kg)	939	943	1149	1253	1268
Operating Weight (5)	(kg)	950	954	1161	1263	1283
Additional weight (dual pump high head)	(kg)	200	200	242	241	256
Additional weight (dual pump standard head)	(kg)	183	183	226	225	226
Additional weight (single pump high head)	(kg)	163	163	205	204	209
Additional weight (single pump standard head)	(kg)	154	154	196	195	196
Louver Weight	(kg)	19	19	25	25	25
Min. Starting/Oper. Ambient						
Std Unit	(°C)	7	7	7	7	7
Low Ambient (Option)	(°C)	-18	-18	-18	-18	-18
Refrigerant and Oil charge per circuit						
Refrigerant charge	(Kg)	22.7	22.7	29	33.6	33.6
Oil Charge	(L)	6.6	6.6	6.6	13.4	13.4

(1) Eurovent Cooling Mode Conditions (Evap. 12°C/7°C - Air. 35°C); Eurovent Heating Mode Condition (Evap. 40°C/45°C-Air. DB/WB 7°C/6°C)

(2) Rated Condition without Pump Package

(3) Single Pump Option

(4) S: Single Speed, D: Two Speed, VFD: Inverter.

(5) Base unit



General Data

Table 11. General Data - CXAM High Efficiency & Compact - Duplex V units

Size		40	46	52	60	70
Eurovent Performances (1)						
Net Cooling Capacity	(kW)	112.5	125.9	149.2	163.5	193.3
Total Power Input in Cooling	(kW)	36.1	41.4	47.3	53.4	63.8
EER		3.1	3.0	3.2	3.1	3.0
Net Heating Capacity	(kW)	126.7	141.8	157.3	177.5	192.5
Total Power Input in Heating	(kW)	37.5	42.4	49.9	56.9	61.5
Heating COP		3.3	3.3	3.2	3.2	3.1
Main Power Supply		400/3/50	400/3/50	400/3/50	400/3/50	400/3/50
Sound Power Level	(dBA)	88	88	90	91	93
System Data						
Refrigerant Circuit	#	2	2	2	2	2
Capacity Steps	%	25-50-75-100	21-43-71-100	25-50-75-100	25-50-75-100	21-43-71-100
Units Amps						
Maximum Amps (2)	(A)	91	99	112	116	137
Start-up Amps (2)						
Standard Unit	(A)	212	232	245	250	315
With Soft Starter Option	(A)	155	169	182	186	229
Short Circuit Unit Capacity	(kA)	15	15	15	15	15
Max Supply Cable Size	(mm ²)	150	150	150	240	240
Compressor						
Compressor Number per Circuit	#	2	2	2	2	2
Type		Scroll	Scroll	Scroll	Scroll	Scroll
Model		CSHD125&CS HD125	CSHD125&CS HD161	CSHD161&CS HD161	CSHN184&CS HN184	CSHN184&CS HN250
Rated Amps per Circuit	(A)	20.7 & 20.7	20.7 & 25	25 & 25	26 & 26	26 & 36.4
Locked Rotor Amps per Circuit	(A)	142 & 142	142 & 158	158 & 158	160 & 160	160 & 215
Motor RPM	(rpm)	2900	2900	2900	2900	2900
Sump heater per circuit	kW	160&160	160&160	160&160	160&160	160&160
Power Factor	#	0.85	0.85	0.85	0.85	0.85
Evaporator						
Quantity	#	1	1	1	1	1
Type		BPHE	BPHE	BPHE	BPHE	BPHE
Water Volume/Storage (Total)	(L)	14.3	14.3	15.6	15.6	28.2
Antifreeze Heater	(W)	300	300	300	300	400
Min. Flow	(L/Sec)	2.6	2.9	3.4	3.8	4.5
Max. Flow	(L/Sec)	7.7	8.6	10.3	11.3	13.4
Pump Package (Option Standard Head)						
Evaporator Head Pressure Available Single Pump	(kPa)	81.4	95.0	76.2	94.3	138.5
Evaporator Head Pressure Available Dual Pump	(kPa)	81.4	95.0	76.2	94.3	138.5
Power (3)	(kW)	3	4	4	4	5.5
Rated Amps (3)	(A)	6.1	7.59	7.59	7.59	10.6
Pump Package (Option High Head)						
Evaporator Head Pressure Available Single Pump	(kPa)	234.4	212.6	183.3	207.4	215.5
Evaporator Head Pressure Available Dual Pump	(kPa)	234.4	212.6	183.3	207.4	215.5
Power (3)	(kW)	5.5	5.5	5.5	7.5	7.5
Rated Amps (3)	(A)	10.6	10.6	10.6	13.8	13.8
Hydraulic Module Components						
Expansion Tank Volume	(L)	25	25	25	25	25
User Volume Expansion Capacity	(L)	50	50	50	50	50
Max. Water-side Operating Pressure without Hydraulic Module	(kPa)	1000	1000	1000	1000	1000
Max. Water-side Operating Pressure with Hydraulic Module	(kPa)	500	500	500	500	500
Antifreeze Heater without pump package and without strainer	(W)			120		
Antifreeze Heater without pump package and with strainer	(W)			120		
Pump package antifreeze Heater	(W)			860		
Buffer tank antifreeze Heater	(W)			800		
VFD Weight	(kg)	15	15	15	15	15

Table 11. General Data - CXAM High Efficiency & Compact - Duplex V units

Size		40	46	52	60	70
Water tank Volume	(L)	500	500	500	500	500
Condenser						
Type		Fin and Tube	Fin and Tube	Fin and Tube	Fin and Tube	Fin and Tube
Tube diameter	(mm)	9.52	9.52	9.52	9.52	9.52
Number of Rows	#	3	3	3	3	3
Fins per Foot	(fpf)	192	192	192	192	192
Fan						
Quantity	#	4	4	6	6	6
Diameter	(mm)	757	757	757	757	757
Drive Type		Direct	Direct	Direct	Direct	Direct
Std Amb. Speeds per Circuit (4)		1xD + 1xS	1xD + 1xS	1xD + 2xS	1xD + 2xS	1xD + 2xS
Low Amb. Speeds per Circuit (Option) (4)		1xVFD + 1xS	1xVFD + 1xS	1xVFD + 2xS	1xVFD + 2xS	1xVFD + 2xS
Airflow per Fan	(m ³ /h)	13059	13061	12250	12823	12827
Static Pressure	(Pa)	0	0	0	0	0
Power per Motor	(kW)	0.8	0.8	0.9	0.8	0.8
Rated Amps per Motor	(A)	1.95	1.95	1.95	1.95	1.95
Motor RPM	(rpm)	920	920	920	920	920
PHR						
Heat-Exchanger Type		Brazed Plates	Brazed Plates	Brazed Plates	Brazed Plates	Brazed Plates
Victaulic Connection	(mm)	38	38	38	38	38
Water Storage Capacity	(L)	0.0671*2	0.0671*2	0.0671*2	0.0915*2	0.0915*2
Unit Water Connection						
Chilled Water	(mm)	65	65	80	80	80
Type (Standard)		Grooved	Grooved	Grooved	Grooved	Grooved
Dimensions						
Unit Length with Buffer Tank	(mm)	3416	3416	4330	4330	4330
Unit Length with VFD	(mm)	3193	3193	4107	4107	4107
Unit Length with Buffer Tank and VFD	(mm)	3704	3704	4618	4618	4618
Unit Length without Buffer Tank or VFD	(mm)	2905	2905	3819	3819	3819
Unit Width	(mm)	2266	2266	2266	2266	2266
Unit Height	(mm)	2150	2150	2150	2150	2150
Weight (Aluminium Fins without louver or VFD)						
Shipping Weight (5)	(kg)	1712	1720	1974	2194	2233
Operating Weight (5)	(kg)	1730	1738	1992	2213	2264
Additional weight (dual pump high head)	(kg)	226	226	227	319	319
Additional weight (dual pump standard head)	(kg)	209	221	222	223	237
Additional weight (single pump high head)	(kg)	179	179	180	222	222
Additional weight (single pump standard head)	(kg)	171	177	179	179	186
Louver Weight	(kg)	32	32	37	37	37
Min. Starting/Oper. Ambient						
Std Unit	(°C)	7	7	7	7	7
Low Ambient (Option)	(°C)	-18	-18	-18	-18	-18
Refrigerant and Oil charge per circuit						
Refrigerant charge	(Kg)	22.7	22.7	29	32.7	32.7
Oil Charge	(L)	6.6	6.6	6.6	13.4	13.4

(1) Eurovent Cooling Mode Conditions (Evap. 12°C/7°C - Air. 35°C); Eurovent Heating Mode Condition (Evap. 40°C/45°C-Air. DB/WB 7°C/6°C)

(2) Rated Condition without Pump Package

(3) Single Pump Option

(4) S: Single Speed, D: Two Speed, VFD: Inverter.

(5) Base unit



General Data

Table 12. General Data - CXAM High Efficiency & Compact - Duplex W units

Size		80	90	100	110	120	140	150
Eurovent Performances (1)								
Net Cooling Capacity	(kW)	231.0	257.0	293.7	311.1	332.5	378.9	402.5
Total Power Input in Cooling	(kW)	70.7	82.1	93.7	103.1	113.3	132.8	144.5
EER		3.3	3.1	3.1	3.0	2.9	2.9	2.8
Net Heating Capacity	(kW)	229.7	250.5	283.8	300.5	316.9	362.2	398.9
Total Power Input in Heating	(kW)	73.4	81.9	92.8	100.7	107.9	127.9	138.3
Heating COP		3.1	3.1	3.1	3.0	2.9	2.8	2.9
Main Power Supply		400/3/50	400/3/50	400/3/50	400/3/50	400/3/50	400/3/50	400/3/50
Sound Power Level	(dBA)	94	93	92	92	93	94	93
System Data								
Refrigerant Circuit	#	2	2	2	2	2	2	2
Capacity Steps	%	25-50-75-100	22-44-72-100	25-50-75-100	23-45-73-100	25-50-75-100	14-29-46-64-82-100	17-33-50-67-83-100
Units Amps								
Maximum Amps (2)	(A)	161	181	205	225	245	282	302
Start-up Amps (2)								
Standard Unit	(A)	340	395	419	489	509	495	515
With Soft Starter Option	(A)	254	291	315	361	381	391	411
Short Circuit Unit Capacity	(kA)	15	15	15	15	15	15	15
Max Supply Cable Size	(mm ²)	240	240	240	240	240	2 x 300	2 x 300
Compressor								
Compressor Number per Circuit	#	2	2	2	2	2	3	3
Type		Scroll	Scroll	Scroll	Scroll	Scroll	Scroll	Scroll
Model		CSHN250 & CSHN250	CSHN250 & CSHN315	CSHN315 & CSHN315	CSHN315 & CSHN374	CSHN374 & CSHN374	CSHN250 & CSHN315 & CSHN315	CSHN315 & CSHN315 & CSHN315
Rated Amps per Circuit	(A)	36.4 & 36.4	36.4 & 46.4	46.4 & 46.4	46.4 & 56.4	56.4 & 56.4	36.4 & 46.4 & 46.4	46.4 & 46.4 & 46.4
Locked Rotor Amps per Circuit	(A)	215 & 215	215 & 260	260 & 260	260 & 320	320 & 320	215 & 260 & 260	260 & 260 & 260
Motor RPM	(rpm)	2900	2900	2900	2900	2900	2900	2900
Sump heater per circuit	kW	160&160	160&160	160&160	160&160	160&160	160&160	160&160
Power Factor	#	0.85	0.85	0.85	0.85	0.85	0.85	0.85
Evaporator								
Quantity	#	1	1	1	1	1	1	1
Type		BPHE	BPHE	BPHE	BPHE	BPHE	BPHE	BPHE
Water Volume/Storage (Total)	(L)	32.4	40.8	46.7	40.8	43.4	46.7	46.7
Antifreeze Heater	(W)	400	500	500	400	500	500	500
Min. Flow	(L/Sec)	5.3	5.9	6.8	7.2	7.7	8.8	9.3
Max. Flow	(L/Sec)	16.0	17.8	20.3	21.6	23.0	26.3	27.9
Pump Package (Option Standard Head)								
Evaporator Head Pressure Available Single Pump	(kPa)	152.5	145.7	117.2	128.9	121.9	143.9	131.1
Evaporator Head Pressure Available Dual Pump	(kPa)	152.5	145.7	117.2	128.9	121.9	143.9	131.1
Power (3)	(kW)	5.5	5.5	5.5	7.5	7.5	11	11
Rated Amps (3)	(A)	10.6	10.6	10.6	13.8	13.8	19.6	19.6
Pump Package (Option High Head)								
Evaporator Head Pressure Available Single Pump	(kPa)	229.0	225.6	203.6	193.2	228.8	201.8	188.6
Evaporator Head Pressure Available Dual Pump	(kPa)	229.0	225.6	203.6	193.2	228.8	201.8	188.6
Power (3)	(kW)	7.5	7.5	7.5	7.5	11	11	11
Rated Amps (3)	(A)	13.8	13.8	13.8	13.8	19.6	19.6	19.6
Hydraulic Module Components								
Expansion Tank Volume	(L)	60	60	60	60	60	60	60
User Volume Expansion Capacity	(L)	900	900	900	900	900	900	900
Max. Water-side Operating Pressure without Hydraulic Module	(kPa)	1000	1000	1000	1000	1000	1000	1000
Max. Water-side Operating Pressure with Hydraulic Module	(kPa)	500	500	500	500	500	500	500
Antifreeze Heater without pump package and without strainer	(W)	120	120	240	240	240	240	240
Antifreeze Heater without pump package and with strainer	(W)	240	240	300	300	300	300	300
Pump package antifreeze Heater	(W)	980	980	1100	1100	1100	1100	1100
Buffer tank antifreeze Heater	(W)	1200	1200	1200	1200	1200	1200	1200

Table 12. General Data - CXAM High Efficiency & Compact - Duplex W units

Size		80	90	100	110	120	140	150
VFD Weight	(kg)	21	21	21	21	21	21	21
Water tank Volume	(L)	725	725	725	725	725	725	725
Condenser								
Type		Fin and Tube	Fin and Tube	Fin and Tube	Fin and Tube	Fin and Tube	Fin and Tube	Fin and Tube
Tube diameter	(mm)	9.52	9.52	9.52	9.52	9.52	9.52	9.52
Number of Rows	#	3	3	3	3	3	3	3
Fins per Foot	(fpf)	192	192	192	192	192	192	192
Fan								
Quantity	#	8	8	10	10	10	12	12
Diameter	(mm)	757	757	757	757	757	757	757
Drive Type		Direct	Direct	Direct	Direct	Direct	Direct	Direct
Std Amb. Speeds per Circuit (4)		4xS	4xS	5xS	5xS	5xS	6xS	6xS
Low Amb. Speeds per Circuit (Option) (4)		1xVFD + 3xS	1xVFD + 3xS	1xVFD + 4xS	1xVFD + 4xS	1xVFD + 4xS	1xVFD + 5xS	1xVFD + 5xS
Airflow per Fan	(m ³ /h)	13012	13015	13013	13014	13016	13015	13017
Static Pressure	(Pa)	0	0	0	0	0	0	0
Power per Motor	(kW)	0.8	0.8	0.8	0.8	0.8	0.8	0.8
Rated Amps per Motor	(A)	1.95	1.95	1.95	1.95	1.95	1.95	1.95
Motor RPM	(rpm)	920	920	920	920	920	920	920
PHR								
Heat-Exchanger Type		Brazed Plates	Brazed Plates	Brazed Plates	Brazed Plates	Brazed Plates	Brazed Plates	Brazed Plates
Victaulic Connection	(mm)	64	64	64	64	64	64	64
Water Storage Capacity	(L)	0.122*2	0.122*2	0.122*2	0.1647*2	0.1647*2	0.2135*2	0.2135*2
Unit Water Connection								
Chilled Water	(mm)	100	100	100	100	100	100	100
Type (Standard)		Grooved	Grooved	Grooved	Grooved	Grooved	Grooved	Grooved
Dimensions								
Unit Length with Buffer Tank	(mm)	4230	4230	5145	5145	5145	6062	6062
Unit Length with VFD	(mm)	4558	4558	5473	5473	5473	6388	6388
Unit Length with Buffer Tank and VFD	(mm)	4558	4558	5473	5473	5473	6388	6388
Unit Length without Buffer Tank or VFD	(mm)	4230	4230	5145	5145	5145	6062	6062
Unit Width	(mm)	2273	2273	2273	2273	2273	2273	2273
Unit Height	(mm)	2344	2344	2344	2344	2344	2344	2344
Weight (Aluminium Fins without louver or VFD)								
Shipping Weight (5)	(kg)	2675	2795	3251	3233	3241	3862	3956
Operating Weight (5)	(kg)	2710	2838	3300	3276	3286	3911	4005
Additional weight (dual pump high head)	(kg)	406	406	429	428	510	557	557
Additional weight (dual pump standard head)	(kg)	325	325	347	427	427	556	556
Additional weight (single pump high head)	(kg)	310	310	332	332	377	423	423
Additional weight (single pump standard head)	(kg)	274	274	296	336	336	423	423
Louver Weight	(kg)	47	47	51	51	51	56	56
Min. Starting/Oper. Ambient								
Std Unit	(°C)	7	7	7	7	7	7	7
Low Ambient (Option)	(°C)	-18	-18	-18	-18	-18	-18	-18
Refrigerant and Oil charge per circuit								
Refrigerant charge	(Kg)	45.4	49	59.2	57.2	59	68.9	72
Oil Charge	(L)	13.4	13.4	13.4	13.9	14.4	22.5	23

(1) Eurovent Cooling Mode Conditions (Evap. 12°C/7°C - Air. 35°C); Eurovent Heating Mode Condition (Evap. 40°C/45°C-Air. DB/WB 7°C/6°C)

(2) Single Pump Option

(3) Rated Condition without Pump Package

(4) S: Single Speed, D: Two Speed, VFD: Inverter.

(5) With pump and antifreeze protection



General Data

Table 13. General Data - CXAM High Efficiency & Super Quiet - Simplex units

Size		20	23	26	30	35
Eurovent Performances (1)						
Net Cooling Capacity	(kW)	57.8	64.2	74.9	80.2	93.9
Total Power Input in Cooling	(kW)	18.3	20.9	23.8	26.8	31.9
EER		3.1	3.1	3.1	3.0	2.9
Net Heating Capacity	(kW)	62.2	69.3	77.1	87.5	99.1
Total Power Input in Heating	(kW)	18.5	21.0	24.3	28.3	31.9
Heating COP		3.4	3.3	3.2	3.1	3.1
Main Power Supply		400/3/50	400/3/50	400/3/50	400/3/50	400/3/50
Sound Power Level	(dBA)	79	80	81	82	84
System Data						
Refrigerant Circuit	#	1	1	1	1	1
Capacity Steps	%	50-100	43-100	50-100	50-100	43-100
Units Amps						
Maximum Amps (2)	(A)	49	53	61	63	73
Start-up Amps (2)						
Standard Unit	(A)	170	186	194	197	252
With Soft Starter Option	(A)	113	123	131	133	166
Short Circuit Unit Capacity	(kA)	15	15	15	15	15
Max Supply Cable Size	(mm ²)	95	95	95	95	150
Compressor						
Compressor Number per Circuit	#	2	2	2	2	2
Type		Scroll	Scroll	Scroll	Scroll	Scroll
Model		CSHD125 & CSHD125	CSHD125 & CSHD161	CSHD161 & CSHD161	CSHN184 & CSHN184	CSHN184 & CSHN250
Rated Amps per Circuit	(A)	20.7 & 20.7	20.7 & 25	25 & 25	26 & 26	26 & 36.4
Locked Rotor Amps per Circuit	(A)	142 & 142	142 & 158	158 & 158	160 & 160	160 & 215
Motor RPM	(rpm)	2900	2900	2900	2900	2900
Sump heater per circuit	kW	90&90	90&90	90&90	160&160	160&160
Power Factor	#	0.85	0.85	0.85	0.85	0.85
Evaporator						
Quantity	#	1	1	1	1	1
Type		BPHE	BPHE	BPHE	BPHE	BPHE
Water Volume/Storage (Total)	(L)	6.7	6.7	8.2	6.3	10.6
Antifreeze Heater	(W)	200	200	200	200	300
Min. Flow	(L/Sec)	1.3	1.5	1.7	1.9	2.2
Max. Flow	(L/Sec)	4.0	4.5	5.2	5.6	6.6
Pump Package (Option Standard Head)						
Evaporator Head Pressure Available Single Pump	(kPa)	113.3	86.9	77.8	69.2	83.6
Evaporator Head Pressure Available Dual Pump	(kPa)	113.3	86.9	77.8	69.2	83.6
Power (3)	(kW)	1.5	1.5	1.5	1.5	1.5
Rated Amps (3)	(A)	3.25	3.25	3.25	3.25	3.25
Pump Package (Option High Head)						
Evaporator Head Pressure Available Single Pump	(kPa)	290.0	262.5	250.7	239.6	249.8
Evaporator Head Pressure Available Dual Pump	(kPa)	290.0	262.5	250.7	239.6	249.8
Power (3)	(kW)	4	4	4	4	5.5
Rated Amps (3)	(A)	7.59	7.59	7.59	7.59	10.6
Hydraulic Module components						
Expansion Tank Volume	(L)	25	25	25	25	25
User Volume Expansion Capacity	(L)	50	50	50	50	50
Max. Water-side Operating Pressure without Hydraulic Module	(kPa)	1000	1000	1000	1000	1000
Max. Water-side Operating Pressure with Hydraulic Module	(kPa)	500	500	500	500	500
Antifreeze Heater without pump package and without strainer	(W)			120		
Antifreeze Heater without pump package and with strainer	(W)			180		
Pump package antifreeze Heater	(W)			530		
Buffer tank antifreeze Heater	(W)			800		

Table 13. General Data - CXAM High Efficiency & Super Quiet - Simplex units

Size		20	23	26	30	35
VFD Weight	(kg)	10	10	10	10	10
Water tank Volume	(L)	506	506	506	506	506
Condenser						
Type		Fin and Tube	Fin and Tube	Fin and Tube	Fin and Tube	Fin and Tube
Tube diameter	(mm)	9.52	9.52	9.52	9.52	9.52
Number of Rows	#	3	3	3	3	3
Fins per Foot	(fpf)	192	192	192	192	192
Fan						
Quantity	#	2	2	3	3	3
Diameter	(mm)	732	732	732	732	732
Drive Type		Direct	Direct	Direct	Direct	Direct
Std Amb. Speeds per Circuit (4)		1xD + 1xS	1xD + 1xS	1xD + 2xS	1xD + 2xS	1xD + 2xS
Low Amb. Speeds per Circuit (Option) (4)		1xVFD + 1xS	1xVFD + 1xS	1xVFD + 2xS	1xVFD + 2xS	1xVFD + 2xS
Airflow per Fan	(m3/h)	12747	12751	11360	12343	12350
Static Pressure	(Pa)	0	0	0	0	0
Power per Motor	(kW)	0.8	0.8	0.8	0.8	0.8
Rated Amps per Motor	(A)	1.80	1.80	1.80	1.80	1.80
Motor RPM	(rpm)	700	700	700	700	700
PHR						
Heat-Exchanger Type		Brazed Plates	Brazed Plates	Brazed Plates	Brazed Plates	Brazed Plates
Victaulic Connection	(mm)	38	38	38	38	38
Water Storage Capacity	(L)	0.0671	0.0671	0.0671	0.0915	0.0915
Unit Water Connection						
Chilled Water	(mm)	50	50	65	65	65
Type (Standard)		Grooved	Grooved	Grooved	Grooved	Grooved
Dimensions						
Unit Length with Buffer Tank	(mm)	3418	3418	4332	4332	4332
Unit Length with VFD	(mm)	2908	2908	3822	3822	3822
Unit Length with Buffer Tank and VFD	(mm)	3418	3418	4332	4332	4332
Unit Length without Buffer Tank or VFD	(mm)	2908	2908	3822	3822	3822
Unit Width	(mm)	1301	1301	1301	1301	1301
Unit Height	(mm)	2153	2153	2153	2153	2153
Weight (Aluminium Fins without louver or VFD)						
Shipping Weight (5)	(kg)	939	943	1149	1253	1268
Operating Weight (5)	(kg)	950	954	1161	1263	1283
Additional weight (dual pump high head)	(kg)	200	200	242	241	256
Additional weight (dual pump standard head)	(kg)	183	183	226	225	226
Additional weight (single pump high head)	(kg)	163	163	205	204	209
Additional weight (single pump standard head)	(kg)	154	154	196	195	196
Additional weight (Buffer tank)	(kg)	188	188	188	189	188
Louver Weight	(kg)	19	19	25	25	25
Min. Starting/Oper. Ambient						
Std Unit	(°C)	7	7	7	7	7
Low Ambient (Option)	(°C)	-18	-18	-18	-18	-18
Refrigerant and Oil charge per circuit						
Refrigerant charge	(Kg)	22.7	22.7	29	33.6	33.6
Oil Charge	(L)	6.6	6.6	6.6	13.4	13.4

(1) Eurovent Cooling Mode Conditions (Evap. 12°C/7°C - Air. 35°C); Eurovent Heating Mode Condition (Evap. 40°C/45°C-Air. DB/WB 7°C/6°C)

(2) Rated Condition without Pump Package

(3) Single Pump Option

(4) S: Single Speed, D: Two Speed, VFD: Inverter.

(5) Base unit



General Data

Table 14. General Data - CXAM High Efficiency & Super Quiet - Duplex V

Size		40	46	52	60	70
Eurovent Performances (1)						
Net Cooling Capacity	(kW)	112.4	125.7	148.1	162.9	192.5
Total Power Input in Cooling	(kW)	36.2	41.6	47.6	53.7	64.2
EER		3.1	3.0	3.1	3.0	3.0
Net Heating Capacity	(kW)	126.4	141.2	156.2	176.8	200.5
Total Power Input in Heating	(kW)	37.3	42.3	49.4	56.6	63.6
Heating COP		3.4	3.3	3.2	3.1	3.2
Main Power Supply		400/3/50	400/3/50	400/3/50	400/3/50	400/3/50
Sound Power Level	(dBA)	82	83	84	85	87
System Data						
Refrigerant Circuit	#	2	2	2	2	2
Capacity Steps	%	25-50-75-100	21-43-71-100	25-50-75-100	25-50-75-100	21-43-71-100
Units Amps						
Maximum Amps (2)	(A)	90	99	111	115	136
Start-up Amps (2)						
Standard Unit	(A)	211	232	244	249	314
With Soft Starter Option	(A)	154	169	181	185	228
Short Circuit Unit Capacity	(kA)	15	15	15	15	15
Max Supply Cable Size	(mm ²)	150	150	150	240	240
Compressor						
Compressor Number per Circuit	#	2	2	2	2	2
Type		Scroll	Scroll	Scroll	Scroll	Scroll
Model		CSHD125 & CSHD125	CSHD125 & CSHD161	CSHD161 & CSHD161	CSHN184 & CSHN184	CSHN184 & CSHN250
Rated Amps per Circuit	(A)	20.7 & 20.7	20.7 & 25	25 & 25	26 & 26	26 & 36.4
Locked Rotor Amps per Circuit	(A)	142 & 142	142 & 158	158 & 158	160 & 160	160 & 215
Motor RPM	(rpm)	2900	2900	2900	2900	2900
Sump heater per circuit	kW	160&160	160&160	160&160	160&160	160&160
Power Factor	#	0.85	0.85	0.85	0.85	0.85
Evaporator						
Quantity	#	1	1	1	1	1
Type		BPHE	BPHE	BPHE	BPHE	BPHE
Water Volume/Storage (Total)	(L)	14.3	14.3	15.6	15.6	28.2
Antifreeze Heater	(W)	300	300	300	300	400
Min. Flow	(L/Sec)	2.6	2.9	3.4	3.8	4.4
Max. Flow	(L/Sec)	7.7	8.6	10.3	11.3	13.3
Pump Package (Option Standard Head)						
Evaporator Head Pressure Available Single Pump	(kPa)	82.5	95.4	78.8	95.5	139.1
Evaporator Head Pressure Available Dual Pump	(kPa)	82.5	95.4	78.8	95.5	139.1
Power (3)	(kW)	3	4	4	4	5.5
Rated Amps (3)	(A)	6.1	7.59	7.59	7.59	10.6
Pump Package (Option High Head)						
Evaporator Head Pressure Available Single Pump	(kPa)	235.6	213.2	186.9	208.3	216.0
Evaporator Head Pressure Available Dual Pump	(kPa)	235.6	213.2	186.9	208.3	216.0
Power (3)	(kW)	5.5	5.5	5.5	7.5	7.5
Rated Amps (3)	(A)	10.6	10.6	10.6	13.8	13.8
Hydraulic Module components						
Expansion Tank Volume	(L)	25	25	25	25	25
User Volume Expansion Capacity	(L)	50	50	50	50	50
Max. Water-side Operating Pressure without Hydraulic Module	(kPa)	1000	1000	1000	1000	1000
Max. Water-side Operating Pressure with Hydraulic Module	(kPa)	500	500	500	500	500
Antifreeze Heater without pump package and without strainer	(W)			120		
Antifreeze Heater without pump package and with strainer	(W)			120		
Pump package antifreeze Heater	(W)			860		
Buffer tank antifreeze Heater	(W)			800		
VFD Weight	(kg)	15	15	15	15	15

Table 14. General Data - CXAM High Efficiency & Super Quiet - Duplex V

Size		40	46	52	60	70
Water tank Volume	(L)	500	500	500	500	500
Condenser						
Type		Fin and Tube	Fin and Tube	Fin and Tube	Fin and Tube	Fin and Tube
Tube diameter	(mm)	9.52	9.52	9.52	9.52	9.52
Number of Rows	#	3	3	3	3	3
Fins per Foot	(fpf)	192	192	192	192	192
Fan						
Quantity	#	4	4	6	6	6
Diameter	(mm)	732	732	732	732	732
Drive Type		Direct	Direct	Direct	Direct	Direct
Std Amb. Speeds per Circuit (4)		1xD + 1xS	1xD + 1xS	1xD + 2xS	1xD + 2xS	1xD + 2xS
Low Amb. Speeds per Circuit (Option) (4)		1xVFD + 1xS	1xVFD + 1xS	1xVFD + 2xS	1xVFD + 2xS	1xVFD + 2xS
Airflow per Fan	(m3/h)	12746	12750	11359	12344	12350
Static Pressure	(Pa)	0	0	0	0	0
Power per Motor	(kW)	0.8	0.8	0.8	0.8	0.8
Rated Amps per Motor	(A)	1.80	1.80	1.80	1.80	1.80
Motor RPM	(rpm)	700	700	700	700	700
PHR						
Heat-Exchanger Type		Brazed Plates	Brazed Plates	Brazed Plates	Brazed Plates	Brazed Plates
Victaulic Connection	(mm)	38	38	38	38	38
Water Storage Capacity	(L)	0.0671*2	0.0671*2	0.0671*2	0.0915*2	0.0915*2
Unit Water Connection						
Chilled Water	(mm)	65	65	80	80	80
Type (Standard)		Grooved	Grooved	Grooved	Grooved	Grooved
Dimensions						
Unit Length with Buffer Tank	(mm)	3416	3416	4330	4330	4330
Unit Length with VFD	(mm)	3193	3193	4107	4107	4107
Unit Length with Buffer Tank and VFD	(mm)	3704	3704	4618	4618	4618
Unit Length without Buffer Tank or VFD	(mm)	2905	2905	3819	3819	3819
Unit Width	(mm)	2266	2266	2266	2266	2266
Unit Height	(mm)	2150	2150	2150	2150	2150
Weight (Aluminium Fins without louver or VFD)						
Shipping Weight (5)	(kg)	1712	1720	1974	2194	2233
Operating Weight (5)	(kg)	1730	1738	1992	2213	2264
Additional weight (dual pump high head)	(kg)	226	226	227	319	319
Additional weight (dual pump standard head)	(kg)	209	221	222	223	237
Additional weight (single pump high head)	(kg)	179	179	180	222	222
Additional weight (single pump standard head)	(kg)	171	177	179	179	186
Additional weight (Buffer tank)	(kg)	188	188	188	189	189
Shipping Weight (7)	(kg)	1938	1946	2201	2513	2552
Louver Weight	(kg)	32	32	37	37	37
Min. Starting/Oper. Ambient						
Std Unit	(°C)	7	7	7	7	7
Low Ambient (Option)	(°C)	-18	-18	-18	-18	-18
Refrigerant and Oil charge per circuit						
Refrigerant charge	(Kg)	22.7	22.7	29	33.6	34
Oil Charge	(L)	6.6	6.6	6.6	13.4	13.4

(1) Eurovent Cooling Mode Conditions (Evap. 12°C/7°C - Air. 35°C); Eurovent Heating Mode Condition (Evap. 40°C/45°C-Air. DB/WB 7°C/6°C)

(2) Single Pump Option

(3) Rated Condition without Pump Package

(4) S: Single Speed, D: Two Speed, VFD: Inverter.

(5) With pump and antifreeze protection



General Data

Table 15. General Data - CXAM High Efficiency & Super Quiet - Duplex W

Size		80	90	100	110	120	140	150
Eurovent Performances (1)								
Net Cooling Capacity	(kW)	231.0	257.2	293.9	311.4	332.9	379.2	403.2
Total Power Input in Cooling	(kW)	70.3	81.7	93.2	102.6	112.8	132.2	143.9
EER		3.3	3.1	3.2	3.0	3.0	2.9	2.8
Net Heating Capacity	(kW)	229.5	250.4	282.9	300.1	317.2	362.2	397.2
Total Power Input in Heating	(kW)	73.1	81.5	92.3	100.2	107.4	127.7	137.2
Heating COP		3.1	3.1	3.1	3.0	3.0	2.8	2.9
Main Power Supply		400/3/50	400/3/50	400/3/50	400/3/50	400/3/50	400/3/50	400/3/50
Sound Power Level	(dBA)	88	87	86	87	88	88	87
System Data								
Refrigerant Circuit	#	2	2	2	2	2	2	2
Capacity Steps	%	25-50-75-100	22-44-72-100	25-50-75-100	23-45-73-100	25-50-75-100	14-29-46-64-82-100	17-33-50-67-83-100
Units Amps								
Maximum Amps (2)	(A)	160	180	204	224	244	280	300
Start-up Amps (2)								
Standard Unit	(A)	339	394	417	487	507	494	514
With Soft Starter Option	(A)	253	290	313	359	379	390	410
Short Circuit Unit Capacity	(kA)	15	15	15	15	15	15	15
Max Supply Cable Size	(mm ²)	240	240	240	240	240	2 x 300	2 x 300
Compressor								
Compressor Number per Circuit	#	2	2	2	2	2	3	3
Type		Scroll	Scroll	Scroll	Scroll	Scroll	Scroll	Scroll
Model		CSHN250 & CSHN250	CSHN250 & CSHN315	CSHN315 & CSHN315	CSHN315 & CSHN374	CSHN374 & CSHN374	CSHN250 & CSHN315 & CSHN315	CSHN315 & CSHN315 & CSHN315
Rated Amps per Circuit	(A)	36.4 & 36.4	36.4 & 46.4	46.4 & 46.4	46.4 & 56.4	56.4 & 56.4	36.4 & 46.4 & 46.4	46.4 & 46.4 & 46.4
Locked Rotor Amps per Circuit	(A)	215 & 215	215 & 260	260 & 260	260 & 320	320 & 320	215 & 260 & 260	260 & 260 & 260
Motor RPM	(rpm)	2900	2900	2900	2900	2900	2900	2900
Sump heater per circuit	kW	160&160	160&160	160&160	160&160	160&160	160&160	160&160
Power Factor	#	0.85	0.85	0.85	0.85	0.85	0.85	0.85
Evaporator								
Quantity	#	1	1	1	1	1	1	1
Type		BPHE	BPHE	BPHE	BPHE	BPHE	BPHE	BPHE
Water Volume/Storage (Total)	(L)	32.4	40.8	46.7	40.8	43.4	46.7	46.7
Antifreeze Heater	(W)	400	500	500	400	500	500	500
Min. Flow	(L/Sec)	5.3	5.9	6.8	7.2	7.7	8.8	9.3
Max. Flow	(L/Sec)	16.0	17.8	20.4	21.6	23.1	26.3	27.9
Pump Package (Option Standard Head)								
Evaporator Head Pressure Available Single Pump	(kPa)	152.4	145.5	117.0	128.8	121.8	143.7	130.9
Evaporator Head Pressure Available Dual Pump	(kPa)	152.4	145.5	117.0	128.8	121.8	143.7	130.9
Power (3)	(kW)	5.5	5.5	5.5	7.5	7.5	11	11
Rated Amps (3)	(A)	10.6	10.6	10.6	13.8	13.8	19.6	19.6
Pump Package (Option High Head)								
Evaporator Head Pressure Available Single Pump	(kPa)	228.9	225.5	203.4	193.1	228.6	201.6	188.3
Evaporator Head Pressure Available Dual Pump	(kPa)	228.9	225.5	203.4	193.1	228.6	201.6	188.3
Power (3)	(kW)	7.5	7.5	7.5	7.5	11	11	11
Rated Amps (3)	(A)	13.8	13.8	13.8	13.8	19.6	19.6	19.6
Hydraulic Module components								
Expansion Tank Volume	(L)	60	60	60	60	60	60	60
User Volume Expansion Capacity	(L)	900	900	900	900	900	900	900
Max. Water-side Operating Pressure without Hydraulic Module	(kPa)	1000	1000	1000	1000	1000	1000	1000
Max. Water-side Operating Pressure with Hydraulic Module	(kPa)	500	500	500	500	500	500	500
Antifreeze Heater without pump package and without strainer	(W)	120	120	240	240	240	240	240
Antifreeze Heater without pump package and with strainer	(W)	240	240	300	300	300	300	300

Table 15. General Data - CXAM High Efficiency & Super Quiet - Duplex W

Size		80	90	100	110	120	140	150
Pump package antifreeze Heater	(W)	980	980	1100	1100	1100	1100	1100
Buffer tank antifreeze Heater	(W)	1200	1200	1200	1200	1200	1200	1200
VFD Weight	(kg)	21	21	21	21	21	21	21
Water tank Volume	(L)	725	725	725	725	725	725	725
Condenser								
Type		Fin and Tube	Fin and Tube	Fin and Tube	Fin and Tube	Fin and Tube	Fin and Tube	Fin and Tube
Tube diameter	(mm)	9.52	9.52	9.52	9.52	9.52	9.52	9.52
Number of Rows	#	3	3	3	3	3	3	3
Fins per Foot	(fpf)	192	192	192	192	192	192	192
Fan								
Quantity	#	8	8	10	10	10	12	12
Diameter	(mm)	732	732	732	732	732	732	732
Drive Type		Direct	Direct	Direct	Direct	Direct	Direct	Direct
Std Amb. Speeds per Circuit (4)		4xS	4xS	5xS	5xS	5xS	6xS	6xS
Low Amb. Speeds per Circuit (Option) (4)		1xVFD + 3xS	1xVFD + 3xS	1xVFD + 4xS	1xVFD + 4xS	1xVFD + 4xS	1xVFD + 5xS	1xVFD + 5xS
Airflow per Fan	(m ³ /h)	13162	13165	13163	13164	13166	13165	13167
Static Pressure	(Pa)	0	0	0	0	0	0	0
Power per Motor	(kW)	0.8	0.8	0.8	0.8	0.8	0.8	0.8
Rated Amps per Motor	(A)	1.80	1.80	1.80	1.80	1.80	1.80	1.80
Motor RPM	(rpm)	700	700	700	700	700	700	700
PHR								
Heat-Exchanger Type		Brazed Plates	Brazed Plates	Brazed Plates	Brazed Plates	Brazed Plates	Brazed Plates	Brazed Plates
Victaulic Connection	(mm)	64	64	64	64	64	64	64
Water Storage Capacity	(L)	0.122*2	0.122*2	0.122*2	0.1647*2	0.1647*2	0.2135*2	0.2135*2
Unit Water Connection								
Chilled Water	(mm)	100	100	100	100	100	100	100
Type (Standard)		Grooved	Grooved	Grooved	Grooved	Grooved	Grooved	Grooved
Dimensions								
Unit Length with Buffer Tank	(mm)	4230	4230	5145	5145	5145	6062	6062
Unit Length with VFD	(mm)	4558	4558	5473	5473	5473	6388	6388
Unit Length with Buffer Tank and VFD	(mm)	4558	4558	5473	5473	5473	6388	6388
Unit Length without Buffer Tank or VFD	(mm)	4230	4230	5145	5145	5145	6062	6062
Unit Width	(mm)	2273	2273	2273	2273	2273	2273	2273
Unit Height	(mm)	2344	2344	2344	2344	2344	2344	2344
Weight (Aluminium Fins without louver or VFD)								
Shipping Weight (5)	(kg)	2675	2795	3251	3233	3241	3862	3956
Operating Weight (5)	(kg)	2710	2838	3300	3276	3286	3911	4005
Additional weight (dual pump high head)	(kg)	406	406	429	428	510	557	557
Additional weight (dual pump standard head)	(kg)	325	325	347	427	427	556	556
Additional weight (single pump high head)	(kg)	310	310	332	332	377	423	423
Additional weight (single pump standard head)	(kg)	274	274	296	336	336	423	423
Additional weight (Buffer tank)	(kg)	188	188	188	188	188	188	188
Louver Weight	(kg)	47	47	51	51	51	56	56
Min. Starting/Oper. Ambient								
Std Unit	(°C)	7	7	7	7	7	7	7
Low Ambient (Option)	(°C)	-18	-18	-18	-18	-18	-18	-18
Refrigerant and Oil charge per circuit								
Refrigerant charge	(Kg)	45.4	46.3	57.2	57.2	56.2	67.1	66.2
Oil Charge	(L)	13.4	13.4	13.4	13.9	14.4	22.5	23

(1) Eurovent Cooling Mode Conditions (Evap. 12°C/7°C - Air. 35°C); Eurovent Heating Mode Condition (Evap. 40°C/45°C-Air. DB/WB 7°C/6°C)

(2) Rated Condition without Pump Package

(3) Single Pump Option

(4) S: Single Speed, D: Two Speed, VFD: Inverter.

(5) Base unit



General Data

Table 16. General Data - CXAM High Efficiency & Comprehensive Acoustic Package - Simplex units

Size		20	23	26	30
Eurovent Performances (1)					
Net Cooling Capacity	(kW)	56.4	64.5	72.8	80.4
Total Power Input in Cooling	(kW)	18.2	20.3	22.9	26.7
EER		3.1	3.2	3.2	3.0
Net Heating Capacity	(kW)	61.2	68.9	76.5	86.5
Total Power Input in Heating	(kW)	17.5	20.7	23.1	26.4
Heating COP		3.1	3.3	3.3	3.3
Main Power Supply		400/3/50	400/3/50	400/3/50	400/3/50
Sound Power Level	(dBA)	77	78	78	79
System Data					
Refrigerant Circuit	#	1	1	1	1
Capacity Steps	%	50-100	43-100	50-100	50-100
Units Amps					
Nominal Amps (2)	(A)	47	54	58	60
Start-up Amps (2)					
Standard Unit	(A)	168	187	191	194
With Soft Starter Option	(A)	111	124	128	130
Short Circuit Unit Capacity	(kA)	15	15	15	15
Max Supply Cable Size	(mm ²)	95	95	95	95
Compressor					
Compressor Number per Circuit	#	2	2	2	2
Type		Scroll	Scroll	Scroll	Scroll
Model		CSHD125 & CSHD125	CSHD125 & CSHD161	CSHD161 & CSHD161	CSHN184 & CSHN184
Rated Amps per Circuit	(A)	20.7 & 20.7	20.7 & 25	25 & 25	26 & 26
Locked Rotor Amps per Circuit	(A)	142 & 142	142 & 158	158 & 158	160 & 160
Motor RPM	(rpm)	2900	2900	2900	2900
Sump heater per circuit	kW	90&90	90&90	90&90	160&160
Power Factor	#	0.85	0.85	0.85	0.85
Evaporator					
Quantity	#	1	1	1	1
Type		BPHE	BPHE	BPHE	BPHE
Water Volume/Storage (Total)	(L)	6.7	6.3	6.3	8.2
Heater Power	(W)	200	200	200	200
Min. Flow	(L/Sec)	1.3	1.5	1.7	1.9
Max. Flow	(L/Sec)	3.9	4.5	5.1	5.6
Pump Package (Option Standard Head)					
Evaporator Head Pressure Available Single Pump	(kPa)	114.3	82.8	64.5	88.1
Evaporator Head Pressure Available Dual Pump	(kPa)	114.3	82.8	64.5	88.1
Power (3)	(kW)	1.5	1.5	1.5	1.5
Rated Amps (3)	(A)	3.25	3.25	3.25	3.25
Pump Package (Option High Head)					
Evaporator Head Pressure Available Single Pump	(kPa)	291.0	258.4	237.7	258.9
Evaporator Head Pressure Available Dual Pump	(kPa)	291.0	258.4	237.7	258.9
Power (3)	(kW)	4	4	4	4
Rated Amps (3)	(A)	7.59	7.59	7.59	7.59
Hydraulic Module components					
Expansion Tank Volume	(L)	25	25	25	25
User Volume Expansion Capacity	(L)	50	50	50	50
Max. Water-side Operating Pressure without Hydraulic Module	(kPa)	1000	1000	1000	1000
Max. Water-side Operating Pressure with Hydraulic Module	(kPa)	500	500	500	500
Antifreeze Heater without pump package and without strainer	(W)		120		
Antifreeze Heater without pump package and with strainer	(W)		180		
Pump package antifreeze Heater	(W)		530		
Buffer tank antifreeze Heater	(W)		800		
VFD Weight	(kg)	10	10	10	10
Water tank Volume	(L)	506	506	506	506
Condenser					

Table 16. General Data - CXAM High Efficiency & Comprehensive Acoustic Package - Simplex units

Size		20	23	26	30
Type		Fin and Tube	Fin and Tube	Fin and Tube	Fin and Tube
Tube diameter	(mm)	9.52	9.52	9.52	9.52
Number of Rows	#	3	3	3	3
Fins per Foot	(fpf)	192	192	192	192
Fan					
Quantity	#	2	3	3	3
Diameter	(mm)	757	757	757	757
Drive Type		Direct	Direct	Direct	Direct
Std Amb. Speeds per Circuit (4)		1xD + 1xS	1xD + 2xS	1xD + 2xS	1xD + 2xS
Low Amb. Speeds per Circuit (Option) (4)		1xVFD + 1xS	1xVFD + 2xS	1xVFD + 2xS	1xVFD + 2xS
Airflow per Fan	(m ³ /h)	9846	9201	9656	9658
Static Pressure	(Pa)	0	0	0	0
Power per Motor	(kW)	0.4	0.4	0.4	0.4
Rated Amps per Motor	(A)	1.35	1.35	1.35	1.35
Motor RPM	(rpm)	700	700	700	700
PHR					
Heat-Exchanger Type		Brazed Plates	Brazed Plates	Brazed Plates	Brazed Plates
Victaulic Connection	(mm)	38	38	38	38
Water Storage Capacity	(L)	0.0671	0.0671	0.0671	0.0915
Unit Water Connection					
Chilled Water	(mm)	50	65	65	65
Type (Standard)		Grooved	Grooved	Grooved	Grooved
Dimensions					
Unit Length with Buffer Tank	(mm)	3418	4332	4332	4332
Unit Length with VFD	(mm)	2908	3822	3822	3822
Unit Length with Buffer Tank and VFD	(mm)	3418	4332	4332	4332
Unit Length without Buffer Tank or VFD	(mm)	2908	3822	3822	3822
Unit Width	(mm)	1301	1301	1301	1301
Unit Height	(mm)	2153	2153	2153	2153
Weight (Aluminium Fins without louver or VFD)					
Shipping Weight (5)	(kg)	973	1173	1197	1305
Operating Weight (5)	(kg)	984	1183	1207	1317
Additional weight (dual pump high head)	(kg)	200	241	242	241
Additional weight (dual pump standard head)	(kg)	183	225	225	225
Additional weight (single pump high head)	(kg)	163	204	205	204
Additional weight (single pump standard head)	(kg)	154	195	196	195
Additional weight (Buffer tank)	(kg)	188	188	188	189
Louver Weight	(kg)	19	25	25	25
Min. Starting/Oper. Ambient					
Std Unit	(°C)	7	7	7	7
Low Ambient (Option)	(°C)	-18	-18	-18	-18
Refrigerant and Oil charge per circuit					
Refrigerant charge	(Kg)	22.7	29.9	33.6	33.6
Oil Charge	(L)	6.6	6.6	6.6	13.4

(1) Eurovent Cooling Mode Conditions (Evap. 12°C/7°C - Air. 35°C); Eurovent Heating Mode Condition (Evap. 40°C/45°C-Air. DB/WB 7°C/6°C)

(2) Rated Condition without Pump Package

(3) Single Pump Option

(4) S: Single Speed, D: Two Speed, VFD: Inverter.

(5) Base unit



General Data

Table 17. General Data - CXAM High Efficiency & Comprehensive Acoustic Package - Duplex V units

Size		40	46	52	60	70
Eurovent Performances (1)						
Net Cooling Capacity	(kW)	109.9	130.0	147.1	159.6	186.3
Total Power Input in Cooling	(kW)	36.0	40.8	46.1	53.3	65.8
EER		3.1	3.2	3.2	3.0	2.8
Net Heating Capacity	(kW)	124.3	139.6	155.2	174.2	197.0
Total Power Input in Heating	(kW)	35.3	41.5	46.5	53.9	60.7
Heating COP		3.5	3.4	3.3	3.2	3.2
Main Power Supply		400/3/50	400/3/50	400/3/50	400/3/50	400/3/50
Sound Power Level	(dBA)	80	81	82	82	85
System Data						
Refrigerant Circuit	#	2	2	2	2	2
Capacity Steps	%	25-50-75-100	21-43-71-100	25-50-75-100	25-50-75-100	21-43-71-100
Units Amps						
Nominal Amps (2)	(A)	88	100	108	112	133
Start-up Amps (2)						
Standard Unit	(A)	210	233	241	246	312
With Soft Starter Option	(A)	153	170	178	182	226
Short Circuit Unit Capacity	(kA)	15	15	15	15	15
Max Supply Cable Size	(mm ²)	150	150	150	240	240
Compressor						
Compressor Number per Circuit	#	2	2	2	2	2
Type		Scroll	Scroll	Scroll	Scroll	Scroll
Model		CSHD125 & CSHD125	CSHD125 & CSHD161	CSHD161 & CSHD161	CSHN184 & CSHN184	CSHN184 & CSHN250
Rated Amps per Circuit	(A)	20.7 & 20.7	20.7 & 25	25 & 25	26 & 26	26 & 36.4
Locked Rotor Amps per Circuit	(A)	142 & 142	142 & 158	158 & 158	160 & 160	160 & 215
Motor RPM	(rpm)	2900	2900	2900	2900	2900
Sump heater per circuit	kW	160&160	160&160	160&160	160&160	160&160
Power Factor	#	0.85	0.85	0.85	0.85	0.85
Evaporator						
Quantity	#	1	1	1	1	1
Type		BPHE	BPHE	BPHE	BPHE	BPHE
Water Volume/Storage (Total)	(L)	14.3	15.6	15.6	15.6	28.2
Heater Power	(W)	300	300	300	300	400
Min. Flow	(L/Sec)	2.5	3.0	3.4	3.7	4.3
Max. Flow	(L/Sec)	7.5	9.0	10.2	11.0	12.9
Pump Package (Option Standard Head)						
Evaporator Head Pressure Available Single Pump	(kPa)	83.3	102.8	78.8	99.5	143.6
Evaporator Head Pressure Available Dual Pump	(kPa)	83.3	102.8	78.8	99.5	143.6
Power (3)	(kW)	3	4	4	4	5.5
Rated Amps (3)	(A)	6.1	7.59	7.59	7.59	10.6
Pump Package (Option High Head)						
Evaporator Head Pressure Available Single Pump	(kPa)	236.5	219.7	186.8	211.3	220.1
Evaporator Head Pressure Available Dual Pump	(kPa)	236.5	219.7	186.8	211.3	220.1
Power (3)	(kW)	5.5	5.5	5.5	7.5	7.5
Rated Amps (3)	(A)	10.6	10.6	10.6	13.8	13.8
Hydraulic Module components						
Expansion Tank Volume	(L)	25	25	25	25	25
User Volume Expansion Capacity	(L)	50	50	50	50	50
Max. Water-side Operating Pressure without Hydraulic Module	(kPa)	1000	1000	1000	1000	1000
Max. Water-side Operating Pressure with Hydraulic Module	(kPa)	500	500	500	500	500
Antifreeze Heater without pump package and without strainer	(W)			120		
Antifreeze Heater without pump package and with strainer	(W)			120		
Pump package antifreeze Heater	(W)			860		
Buffer tank antifreeze Heater	(W)			800		
VFD Weight	(kg)	15	15	15	15	15

Table 17. General Data - CXAM High Efficiency & Comprehensive Acoustic Package - Duplex V units

Size		40	46	52	60	70
Water tank Volume	(L)	500	500	500	500	500
Condenser						
Type		Fin and Tube	Fin and Tube	Fin and Tube	Fin and Tube	Fin and Tube
Tube diameter	(mm)	9.52	9.52	9.52	9.52	9.52
Number of Rows	#	3	3	3	3	3
Fins per Foot	(fpf)	192	192	192	192	192
Fan						
Quantity	#	4	6	6	6	6
Diameter	(mm)	757	757	757	757	757
Drive Type		Direct	Direct	Direct	Direct	Direct
Std Amb. Speeds per Circuit (4)		1xD + 1xS	1xD + 2xS	1xD + 2xS	1xD + 2xS	1xD + 2xS
Low Amb. Speeds per Circuit (Option) (4)		1xVFD + 1xS	1xVFD + 2xS	1xVFD + 2xS	1xVFD + 2xS	1xVFD + 2xS
Airflow per Fan	(m3/h)	9845	9201	9656	9658	9662
Static Pressure	(Pa)	0	0	0	0	0
Power per Motor	(kW)	0.4	0.4	0.4	0.4	0.4
Rated Amps per Motor	(A)	1.35	1.35	1.35	1.35	1.35
Motor RPM	(rpm)	700	700	700	700	700
PHR						
Heat-Exchanger Type		Brazed Plates	Brazed Plates	Brazed Plates	Brazed Plates	Brazed Plates
Victaulic Connection	(mm)	38	38	38	38	38
Water Storage Capacity	(L)	0.0671*2	0.0671*2	0.0671*2	0.0915*2	0.0915*2
Unit Water Connection						
Chilled Water	(mm)	65	80	80	80	80
Type (Standard)		Grooved	Grooved	Grooved	Grooved	Grooved
Dimensions						
Unit Length with Buffer Tank	(mm)	3416	4330	4330	4330	4330
Unit Length with VFD	(mm)	3193	4107	4107	4107	4107
Unit Length with Buffer Tank and VFD	(mm)	3704	4618	4618	4618	4618
Unit Length without Buffer Tank or VFD	(mm)	2905	3819	3819	3819	3819
Unit Width	(mm)	2266	2266	2266	2266	2266
Unit Height	(mm)	2150	2150	2150	2150	2150
Weight (Aluminium Fins without louver or VFD)						
Shipping Weight (5)	(kg)	1780	2034	2083	2284	2323
Operating Weight (5)	(kg)	1798	2052	2102	2303	2354
Additional weight (dual pump high head)	(kg)	226	227	227	319	319
Additional weight (dual pump standard head)	(kg)	209	222	223	223	237
Additional weight (single pump high head)	(kg)	179	180	180	222	222
Additional weight (single pump standard head)	(kg)	171	179	179	179	186
Additional weight (Buffer tank)	(kg)	188	188	188	189	189
Louver Weight	(kg)	32	37	37	37	37
Min. Starting/Oper. Ambient						
Std Unit	(°C)	7	7	7	7	7
Low Ambient (Option)	(°C)	-18	-18	-18	-18	-18
Refrigerant and Oil charge per circuit						
Refrigerant charge	(Kg)	22.7	29.9	33.6	34.5	34.5
Oil Charge	(L)	6.6	6.6	6.6	13.4	13.4

(1) Eurovent Cooling Mode Conditions (Evap. 12°C/7°C - Air. 35°C); Eurovent Heating Mode Condition (Evap. 40°C/45°C-Air. DB/WB 7°C/6°C)

(2) Rated Condition without Pump Package

(3) Single Pump Option

(4) S: Single Speed, D: Two Speed, VFD: Inverter.

(5) Base unit



General Data

Table 18. General Data - CXAM High Efficiency & Comprehensive Acoustic Package - Duplex W units

Size		80	90	100	110	120
Eurovent Performances (1)						
Net Cooling Capacity	(kW)	227.0	250.8	286.8	311.1	332.7
Total Power Input in Cooling	(kW)	71.9	82.5	95.4	100.8	111.3
EER		3.2	3.0	3.0	3.1	3.0
Net Heating Capacity	(kW)	224.4	245.9	276.2	301.5	320.1
Total Power Input in Heating	(kW)	68.9	77.8	87.8	96.5	103.8
Heating COP		3.3	3.2	3.1	3.1	3.1
Main Power Supply		400/3/50	400/3/50	400/3/50	400/3/50	400/3/50
Sound Power Level	(dBA)	86	85	83	84	85
System Data						
Refrigerant Circuit	#	2	2	2	2	2
Capacity Steps	%	25-50-75-100	22-44-72-100	25-50-75-100	23-45-73-100	25-50-75-100
Units Amps						
Nominal Amps (2)	(A)	156	176	199	222	242
Start-up Amps (2)						
Standard Unit	(A)	335	390	413	485	505
With Soft Starter Option	(A)	249	286	309	357	377
Short Circuit Unit Capacity	(kA)	15	15	15	15	15
Max Supply Cable Size	(mm ²)	240	240	240	240	240
Compressor						
Compressor Number per Circuit	#	2	2	2	2	2
Type		Scroll	Scroll	Scroll	Scroll	Scroll
Model		CSHN250 & CSHN250	CSHN250 & CSHN315	CSHN315 & CSHN315	CSHN315 & CSHN374	CSHN374 & CSHN374
Rated Amps per Circuit	(A)	36.4 & 36.4	36.4 & 46.4	46.4 & 46.4	46.4 & 56.4	56.4 & 56.4
Locked Rotor Amps per Circuit	(A)	215 & 215	215 & 260	260 & 260	260 & 320	320 & 320
Motor RPM	(rpm)	2900	2900	2900	2900	2900
Sump heater per circuit	kW	160&160	160&160	160&160	160&160	160&160
Power Factor	#	0.85	0.85	0.85	0.85	0.85
Evaporator						
Quantity	#	1	1	1	1	1
Type		BPHE	BPHE	BPHE	BPHE	BPHE
Water Volume/Storage (Total)	(L)	39.2	39.2	46.7	43.4	46.7
Heater Power	(W)	400	400	500	500	500
Min. Flow	(L/Sec)	5.2	5.8	6.6	7.2	7.7
Max. Flow	(L/Sec)	15.7	17.4	19.9	21.6	23.0
Pump Package (Option Standard Head)						
Evaporator Head Pressure Available Single Pump	(kPa)	161.0	148.7	122.8	131.2	119.3
Evaporator Head Pressure Available Dual Pump	(kPa)	161.0	148.7	122.8	131.2	119.3
Power (3)	(kW)	5.5	5.5	5.5	7.5	7.5
Rated Amps (3)	(A)	10.6	10.6	10.6	13.8	13.8
Pump Package (Option High Head)						
Evaporator Head Pressure Available Single Pump	(kPa)	237.7	227.6	208.0	195.8	226.1
Evaporator Head Pressure Available Dual Pump	(kPa)	237.7	227.6	208.0	195.8	226.1
Power (3)	(kW)	7.5	7.5	7.5	7.5	11
Rated Amps (3)	(A)	13.8	13.8	13.8	13.8	19.6
Hydraulic Module components						
Expansion Tank Volume	(L)	60	60	60	60	60
User Volume Expansion Capacity	(L)	900	900	900	900	900
Max. Water-side Operating Pressure without Hydraulic Module	(kPa)	1000	1000	1000	1000	1000
Max. Water-side Operating Pressure with Hydraulic Module	(kPa)	500	500	500	500	500
Antifreeze Heater without pump package and without strainer	(W)	120	240	240	240	240
Antifreeze Heater without pump package and with strainer	(W)	240	300	300	300	300
Pump package antifreeze Heater	(W)	980	1100	1100	1100	1100
Buffer tank antifreeze Heater	(W)	1200	1200	1200	1200	1200
VFD Weight	(kg)	21	21	21	21	21
Water tank Volume	(L)	725	725	725	725	725
Condenser						
Type		Fin and Tube	Fin and Tube	Fin and Tube	Fin and Tube	Fin and Tube

Table 18. General Data - CXAM High Efficiency & Comprehensive Acoustic Package - Duplex W units

Size		80	90	100	110	120
Tube diameter	(mm)	9.52	9.52	9.52	9.52	9.52
Number of Rows	#	3	3	3	3	3
Fins per Foot	(fpf)	192	192	192	192	192
Fan						
Quantity	#	8	8	10	12	12
Diameter	(mm)	757	757	757	757	757
Drive Type		Direct	Direct	Direct	Direct	Direct
Std Amb. Speeds per Circuit (4)		4×S	4×S	5×S	6×S	6×S
Low Amb. Speeds per Circuit (Option) (4)		1×VFD + 3×S	1×VFD + 3×S	1×VFD + 4×S	1×VFD + 5×S	1×VFD + 5×S
Airflow per Fan	(m ³ /h)	9807	10301	9807	9805	9807
Static Pressure	(Pa)	0	0	0	0	0
Power per Motor	(kW)	0.4	0.3	0.4	0.4	0.4
Rated Amps per Motor	(A)	1.35	1.35	1.35	1.35	1.35
Motor RPM	(rpm)	700	700	700	700	700
PHR						
Heat-Exchanger Type		Brazed Plates	Brazed Plates	Brazed Plates	Brazed Plates	Brazed Plates
Victaulic Connection	(mm)	64	64	64	64	64
Water Storage Capacity	(L)	0.122*2	0.122*2	0.122*2	0.1647*2	0.1647*2
Unit Water Connection						
Chilled Water	(mm)	100	100	100	100	100
Type (Standard)		Grooved	Grooved	Grooved	Grooved	Grooved
Dimensions						
Unit Length with Buffer Tank	(mm)	4230	5145	5145	6062	6062
Unit Length with VFD	(mm)	4558	5473	5473	6388	6388
Unit Length with Buffer Tank and VFD	(mm)	4558	5473	5473	6388	6388
Unit Length without Buffer Tank or VFD	(mm)	4230	5145	5145	6062	6062
Unit Width	(mm)	2273	2273	2273	2273	2273
Unit Height	(mm)	2344	2344	2344	2344	2344
Weight (Aluminium Fins without louver or VFD)						
Shipping Weight (5)	(kg)	2810	3158	3365	3741	3752
Operating Weight (5)	(kg)	2851	3199	3414	3787	3800
Additional weight (dual pump high head)	(kg)	406	428	429	475	556
Additional weight (dual pump standard head)	(kg)	324	347	347	473	473
Additional weight (single pump high head)	(kg)	310	332	332	378	423
Additional weight (single pump standard head)	(kg)	274	296	296	382	382
Additional weight (Buffer tank)	(kg)	188	188	188	189	188
Louver Weight	(kg)	47	51	51	56	56
Min. Starting/Oper. Ambient						
Std Unit	(°C)	7	7	7	7	7
Low Ambient (Option)	(°C)	-18	-18	-18	-18	-18
Refrigerant and Oil charge per circuit						
Refrigerant charge	(Kg)	45.4	54.4	56.2	66.2	66.2
Oil Charge	(L)	13.4	13.4	13.4	13.9	14.4

(1) Eurovent Cooling Mode Conditions (Evap. 12°C/7°C - Air. 35°C); Eurovent Heating Mode Condition (Evap. 40°C/45°C-Air. DB/WB 7°C/6°C)

(2) Rated Condition without Pump Package

(3) Single Pump Option

(4) S: Single Speed, D: Two Speed, VFD: Inverter.

(5) Base unit



Controls

LCD Touch-Screen Display with Multi-Language Support

The standard DynaView display provided with the Trane CH530 control panel features an LCD touch-screen that is navigated by file tabs. This is an advanced interface that allows the user to access any important information concerning setpoints, active temperatures, modes, electrical data, pressure, and diagnostics. It uses full text display available in 18 languages.

Display Features Include:

- LCD touch-screen with LED backlighting, for scrolling access to input and output operating information
- Single-screen, folder/tab-style display of all available information on individual components (evaporator, condenser, compressor, etc.)
- Password entry/lockout system to enable or disable display
- Automatic and immediate stop capabilities for standard or immediate manual shutdown
- Fast, easy access to available chiller data in tabbed format, including:
 - Modes of operation, including normal cooling and heating as well as ice making
 - Water temperatures and setpoints
 - Loading and limiting status and setpoints
 - Outdoor air temperature
 - Start/stop differential timers
 - Pump status and override
 - Chilled and hot water reset settings
- Optional external setpoints, including:
 - Chilled and hot water
 - Demand limit
 - Ice building

Reports, listed on a single tabbed screen for easy access, including:

- ASHRAE, containing all guideline 3 report information
- Evaporator
- Condenser
- Compressor

Evaporator, condenser, and compressor reports containing all operational information on individual components, including:

- Water temperatures
- Refrigerant pressures, temperatures, and approach
- Flow switch status
- EXV position
- Compressor starts and run-time

Alarm and diagnostic information, including:

- Flashing alarms with touch-screen button for immediate address of alarm condition
- Scrollable list of last ten active diagnostics
- Specific information on applicable diagnostic from list of over one-hundred
- Automatic or manual resetting diagnostic types

Adaptive Controls

Adaptive Controls directly sense the control variables that govern the operation of the unit: evaporator pressure and condenser pressure. When any one of these variables approaches a limit condition when damage may occur to the unit or shutdown on a safety, Adaptive Controls takes corrective action to avoid shutdown and keep the unit operating. This happens through combined actions of compressor and/or fan staging. Whenever possible, the unit is allowed to continue making chilled or hot water. This keeps cooling capacity available until the problem can be solved. Overall, the safety controls help keep the building or process running and out of trouble.

Stand-Alone Controls

Single heat pumps installed in applications without a building management system is simple to install and control: only a remote auto/stop for scheduling is required for unit operation. Signals from the hot/chilled-water pump contactor auxiliary, or a flow switch, are wired to the hot/chilled-water flow interlock. Signals from a time clock or some other remote device are wired to the external auto/stop input.

Standard Features

- Auto/Stop - A job-site provided contact closure turns the unit on and off.
- External Interlock - A job-site provided contact opening wired to this input turns the unit off and require a manual reset of the unit microcomputer. This closure is typically triggered by a job-site provided system such as a fire alarm.

Hardwire Points

Microcomputer controls allow simple interface with other control systems, such as time clocks, building automation systems, and ice storage systems via hardwire points. This means you have the flexibility to meet job requirements while not having to learn a complicated control system.

Remote devices are wired from the control panel to provide auxiliary control to a building automation system. Inputs and outputs can be communicated via a typical 4–20 mA electrical signal, an equivalent 2–10 Vdc signal, or by utilizing contact closures.

This setup has the same stand features as a stand-alone water chiller, with the possibility of having additional optional features:

- Ice making control
- External chilled or hot water setpoint
- External demand limit setpoint
- Chilled water temperature reset
- Programmable relays - available outputs are: alarm-latching, alarm-auto reset, general alarm, warning, chiller limit mode, compressor running, and Tracer control

LonTalk LCI-C Interface with Modbus Interface

LonTalk (LCI-C) with ModBus communications capabilities are available, with communication link via single twisted-pair wiring to factory-installed, tested communication board.

Required features:

- LonTalk LC I-C Interface w/ Modbus Interface
- Protocol Interface Controller

Modbus is a messaging structure developed by the Modicon to transfer and register data between control devices. Modbus is a membership-based trade association that seeks to drive the adoption of the Modbus communication protocol as the messaging structure that devices support. Modbus is a system level communications protocol.

BACnet Interface

BACnet interface capabilities are available, with communication link via single twisted-pair wiring to a factory-installed and tested communication board.

Required features:

- BACnet Interface (selectable option with chiller)

BACnet is a data communication protocol for building automation and control networks developed by American Society of Heating, Refrigerating and Air-Conditioning Engineers (ASHRAE).

LonTalk LCI-C Interface

LonTalk (LCI-C) communications capabilities are available, with communication link via single twisted-pair wiring to factory-installed, tested communication board.

Required features:

- LonTalk/Tracer Summit Interface (selectable option with chiller)

LonTalk is a communications protocol developed by the Echelon Corporation. The LonMark association develops control profiles using the LonTalk communication protocol. LonTalk is a unit level communications protocol.

LonTalk Communications Interface for Chillers (LCI-C) provides a generic automation system with the LonMark chiller profile inputs/outputs. In addition to the standard points, Trane provides other commonly used network output variables for greater interoperability with any automation system. The complete reference list of Trane LonTalk points is available on the LonMark web site.

Trane controls or another vendor's system can use the predefined list of points with ease to give the operator a complete picture of how the system is running



Controls

Tracer Summit

The chiller plant control capabilities of the Trane Tracer Summit building automation system are unequaled in the industry. Trane's depth of experience in chillers and controls makes us a well-qualified choice for automation of chiller plants using air-cooled AquaStream3G chillers and heat pumps. Our chiller plant automation software is fully pre-engineered and tested.

Required features:

- LonTalk/Tracer Summit Interface (selectable option with CGAM/CXAM)
- Building Control Unit (external device required)

Energy Efficiency

- Sequences starting of units to optimize the overall chiller plant energy efficiency
 - Individual units operate as base, peak, or swing based on capacity and efficiency
 - Automatically rotates individual unit operation to equalize runtime and wear between chillers.
 - Evaluates and selects the lowest energy consumption alternative from an overall system perspective.

Easy Operation and Maintenance

- Remote monitoring and control
- Displays both current operation conditions and scheduled automated control actions
- Concise reports assist in planning for preventative maintenance and verifying performance
- Alarm notification and diagnostic messages aid in quick and accurate troubleshooting

When integrated with a Tracer Summit building management system the total building operation can be optimized. With this system option, the full breadth of Trane's HVAC and controls experience are applied to offer solutions to many facility issues. If your project calls for an interface to other systems, Tracer Summit can share data via BACnet an open systems protocol.

Time of Day Scheduling

Time of day scheduling allows the customer to perform simple unit scheduling without the need for a building automation system.

This feature allows the user to set ten events in a seven day time period. For each event the user can specify an activation time and the days of the week the event is active. Any available setpoints can be specified for each event, such as the leaving chilled water temperature (standard) and the demand limit setpoint (optional if ordered).

Required features:

- Time of day scheduling (selectable option with chiller)

Additional options that if ordered may be incorporated into the scheduling:

- External chilled or hot water setpoint
- External demand limit setpoint
- Ice-making initiation

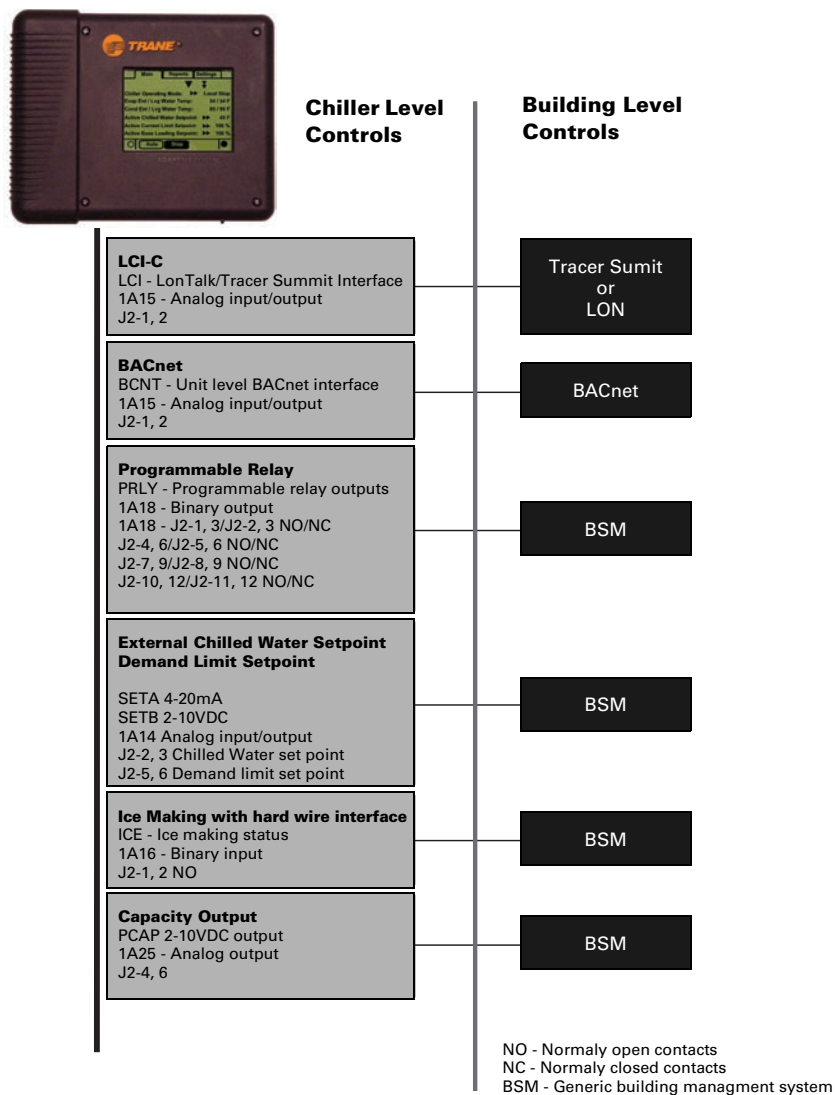

Dimensions

Table 19. Dimensions

# of Circuits	Comp. Manifold			Size	High Efficiency CXAM			Standard Efficiency CXAM		
					Compact	Super Quiet	Comprehensive acoustic package	Compact	Super Quiet	Comprehensive acoustic package
1	10	10		020	Simplex Frame 1			Simplex Frame 1		
1	10	13		023						
1	13	13		026	Simplex Frame 2			Simplex Frame 1		
1	15	15		030						
1	15	20		035	Simplex Frame 2			Simplex Frame 2		
1	20	20		039						
1	20	25		045				Simplex Frame 2		
1	25	25		050						
2	10	10		040	V Frame 1			V Frame 1		
2	10	13		046				V Frame 2		
2	13	13		052				V Frame 1		
2	15	15		060	V Frame 2			V Frame 2		
2	15	20		070						
2	20	20		080	W Frame 2			V Frame 2		
2	20	25		090	W Frame 2		W Frame 3	W Frame 2		W Frame 2
2	25	25		100	W Frame 3		W Frame 3	W Frame 2		W Frame 2
2	25	30		110			W Frame 4	W Frame 2		W Frame 3
2	30	30		120	W Frame 3		W Frame 4	W Frame 2		W Frame 3
2	20	20	25	130				W Frame 3		W Frame 4
2	20	25	25	140	W Frame 4			W Frame 3		W Frame 4
2	25	25	25	150				W Frame 4		W Frame 4
2	25	25	30	160				W Frame 4		W Frame 4
2	25	30	30	170				W Frame 4		W Frame 4

Figure 4. Standard unit - SIMPLEX configuration

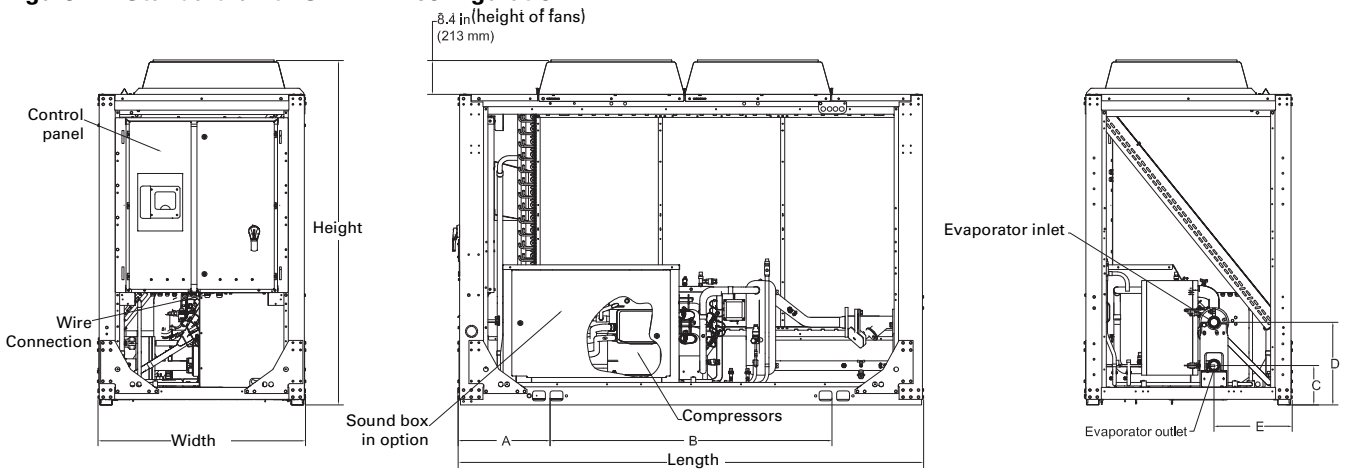

Figure 5. Unit with Pump Package - SIMPLEX configuration

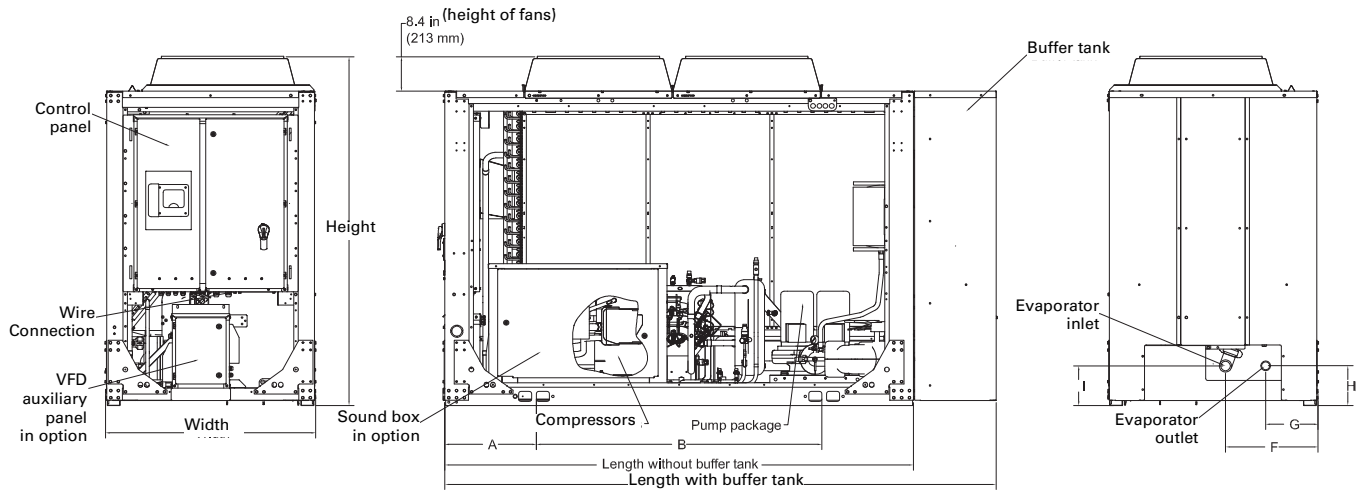
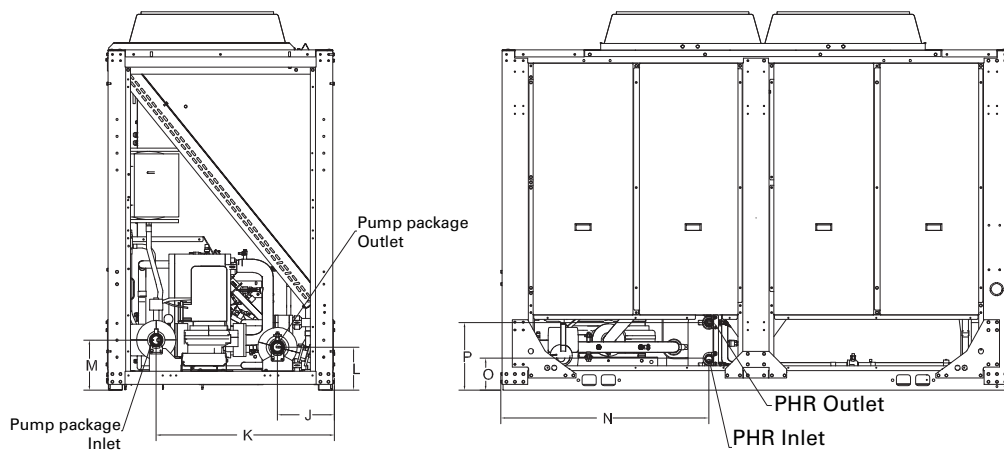

Figure 6. Pump package Water Connections - SIMPLEX configuration



Dimensions

Figure 7. SIMPLEX configuration

Service clearance

Mounting locations

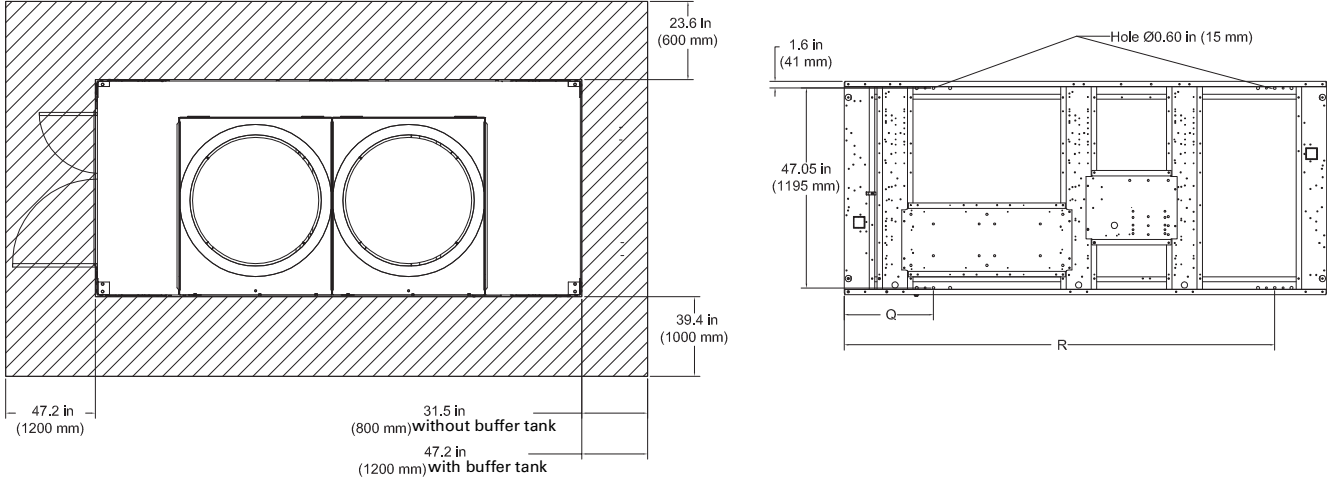

Figure 8. Standard unit + DUPLEX V configuration

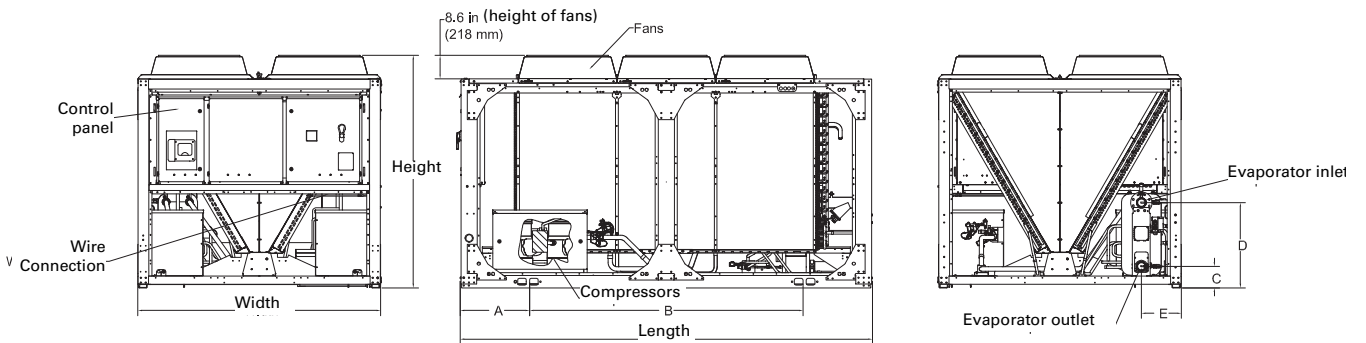

Figure 9. Units with Pump Package - DUPLEX V configuration

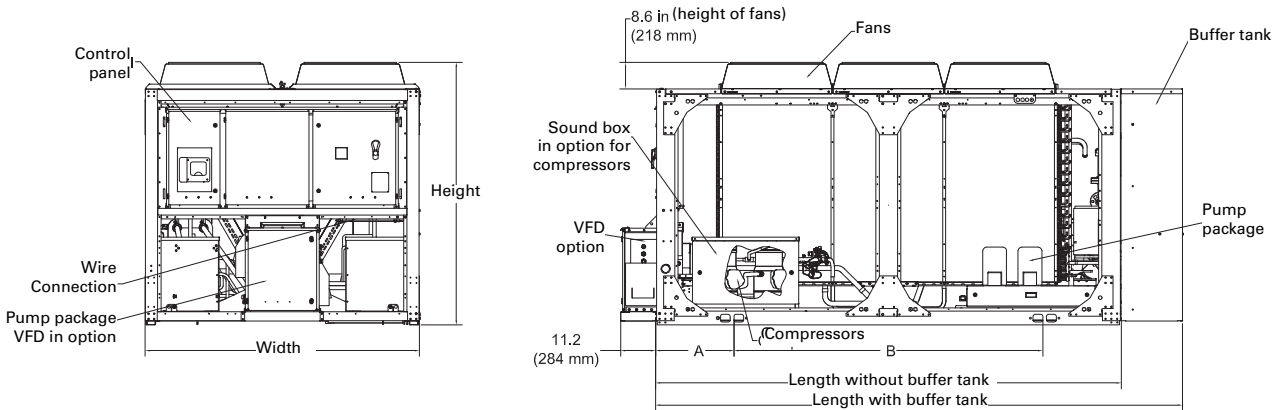

Figure 10. Pump Package Water Connections - DUPLEX V configuration

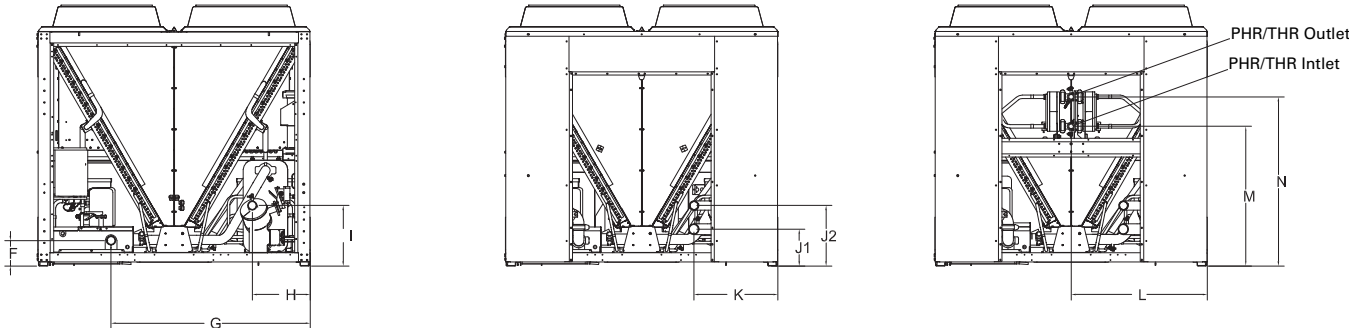

Figure 11. DUPLEX V configuration
Service clearance

Mounting locations

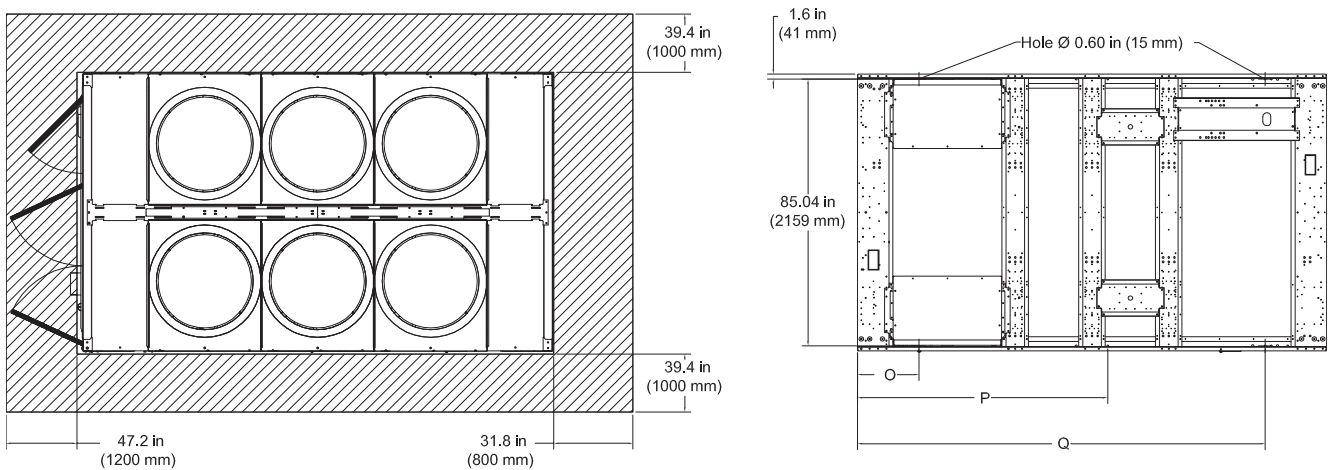
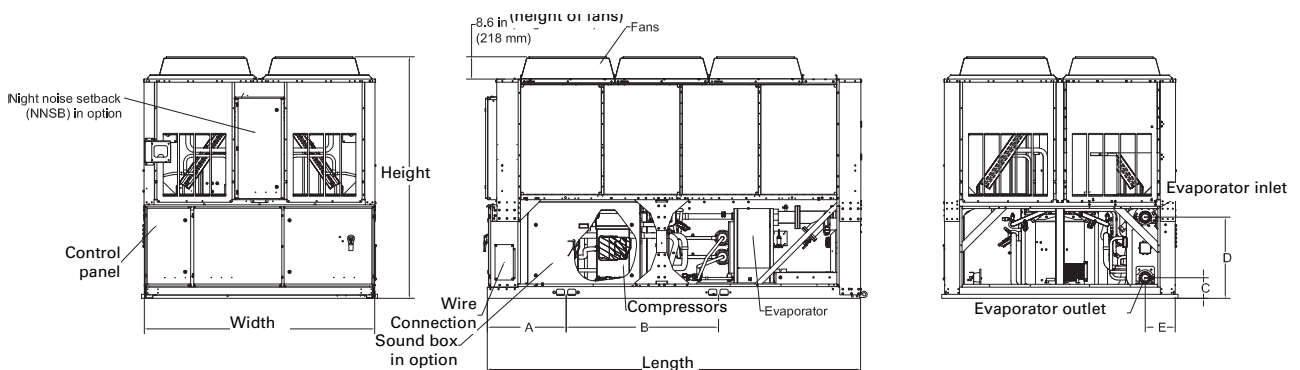

Figure 12. Standard Unit - DUPLEX W configuration



Dimensions

Figure 13. Units with Pump Package - DUPLEX W configuration

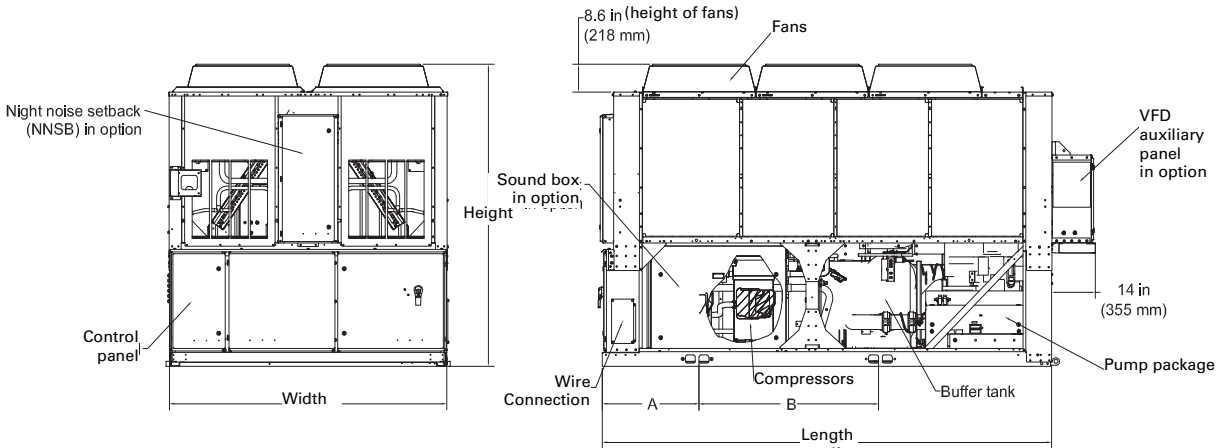

Figure 14. Pump Package Water Connections - DUPLEX W configuration

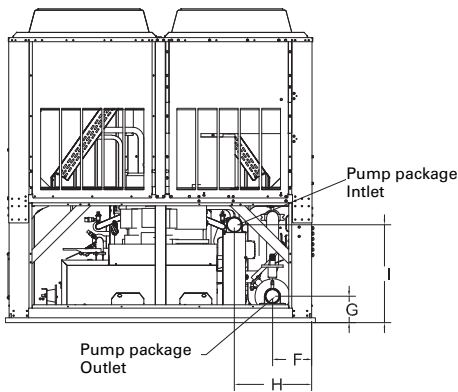

Figure 15. DUPLEX W configuration

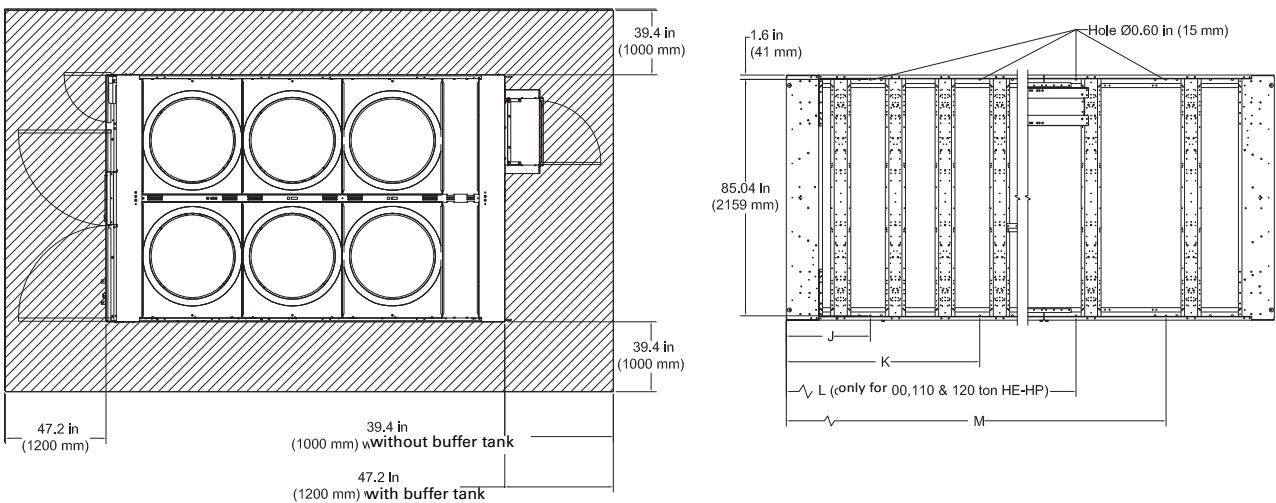

Table 20. Dimensions SIMPLEX

	Unit	FRAME 1	FRAME 2
		$\alpha \rightarrow$ Without buffer tank $b \rightarrow$ With buffer tank	$\alpha \rightarrow$ Without buffer tank $b \rightarrow$ With buffer tank
		mm	mm
	Length	$\alpha \rightarrow$ 2908 $b \rightarrow$ 3388	$\alpha \rightarrow$ 3822 $b \rightarrow$ 4302
	Width	1301	1301
	Height	2145	2145
Lifting holes	A	534	556
	B	1867	2720
EVP water connections (base unit)	C	246	246
	D	516	516
EVP water connections (unit with buffer tank)	E	488	488
	F	572	572
	G	325	325
	H	249	249
EVP water connections (unit with pump package, without buffer tank)	I	244	244
	J	323	323
	K	1016	1016
	L	246	246
Partial Heat Recovery water connections	M	287	287
	N	1176	2091
	O	182	182
Isolators position	P	385	385
	Q	534	558
	R	2571	3358

Table 21. Dimensions Duplex V

	Unit	FRAME 1	FRAME 2
		$\alpha \rightarrow$ Without buffer tank $b \rightarrow$ With buffer tank	$\alpha \rightarrow$ Without buffer tank $b \rightarrow$ With buffer tank
		mm	mm
	Length	$\alpha \rightarrow$ 2905 $b \rightarrow$ 3416	$\alpha \rightarrow$ 3819 $b \rightarrow$ 4330
	Width	2266	2266
	Height	2150	2150
Lifting holes	A	615	615
	B	1650	2564
EVP water connections (base unit)	C	198	198
	D	655	790
	E	371	371
EVP water connections (unit with pump package, without buffer tank)	F	211	211
	G	1646	1646
	H	480	480
	I	500	500
EVP water connections (unit with buffer tank)	J1	303	303
	J2	695	695
	K	1796	1796
Partial Heat Recovery water connections	L	1125	1125
	M	1158	1158
	N	1392	1392
Isolators position	O	494	494
	P		2027
	Q	2388	3299

Dimensions

Table 22. Dimensions DUPLEX W

		FRAME1	FRAME2	FRAME3	FRAME4
	Unit	mm	mm	mm	mm
	Length	3647	4230	5145	6062
	Width	2273	2273	2273	2273
	Height	2344	2344	2344	2344
Lifting holes	A	767	767	767	767
	B	1647	2155	3023	3810
EVP water connections (base unit)	C	198	198	198	198
	D	790	790	790	790
	E	292	292	292	292
EVP water connections (unit with pump package, without buffer tank)	F	292	292	292	292
	G	198	198	198	198
	H	574	574	574	574
	I	734	734	734	734
Isolators position	J	767	767	767	767
	K	2126	2267	1767	1767
	L			3317	4139
	M	3148	3731	4139	5566

Mechanical Specifications

General

- Operates with HFC-based refrigerant R410A.
- Furnished with scroll compressors, brazed plate evaporator, with microprocessor-based control
- Complies with EC requirements for Machinery, Electromagnetic and Pressure Equipment Directives (98/37/CE directive), as amended, and with national implementing legislation
- Manufactured and tested in accordance with the quality assurance ISO 9001/BS EN ISO9001
- Manufactured and tested in ISO 14001 certified factories for a better respect of the environment
- Certified and rated in accordance with Eurovent standards
- Units are constructed of galvanized steel frame with galvanized steel panels
- Component surfaces are finished with a powder-coated paint
- Each unit ships with full operating charges of refrigerant and oil

Compressor and Motor

The unit is equipped with two or more hermetic, direct-drive, 3000 rpm 50 Hz suction gas-cooled scroll compressors. The simple design has only three major moving parts and a completely enclosed compression chamber which leads to increased efficiency. Overload protection is internal to the compressors. The compressor includes: centrifugal oil pump, oil level sight glass and oil charging valve. Each compressor will have compressor heaters installed and properly sized to minimize the amount of liquid refrigerant present in the oil sump during off cycles.

Unit-Mounted Starter

The control panel is designed per IP-54. The starter is available in a solid-state soft starter or across-the-line configuration, factory-mounted and fully pre-wired to the compressor motor and control panel. Power line connection type is standard with a fused disconnect switch.

Disconnect Switch

A non-fused molded case disconnect switch, factory pre-wired with terminal power and equipped with a lockable external operator handle, is available to disconnect the chiller from main power.

Evaporator (Condenser for CXAM in heating mode)

Braze plate heat exchanger is made of stainless steel with copper as the braze material. It is designed to withstand a refrigerant side working pressure of 45 bars and a waterside working pressure of 10.0 bars. Evaporator is tested at 1.1 times maximum allowable refrigerant side working pressure and 1.5 times maximum allowable water side working pressure. It has one water pass.

Blanket heater secures the evaporator from freezing to an ambient of -18°C.

The evaporator is covered with factory-installed 0.75 inch (19.05 mm) Armaflex II or equal (k=0.28) insulation. Foam insulation is used on the suction line. Water pipe extensions with insulation go from the evaporator to the edge of the unit.

All evaporators are tested and stamped in accordance with PED.

Mechanical Specifications

Condenser (Evaporator for CXAM in cooling mode)

Air-cooled coils have aluminium fins mechanically bonded to internally-finned copper tubing. The condenser coil has an integral subcooling circuit. The maximum allowable working pressure of the condenser is 45.0 bars. Condensers are factory proof and leak tested at 50.0 bars.

Direct-drive vertical discharge condenser fans are balanced. Three-phase condenser fan motors with permanently lubricated ball bearings and external thermal overload protection are provided.

Cooling only units (CGAM) are able to operate from -18°C to 52°C ambient.

Reversible units (CXAM) in cooling mode are able to operate from -10°C to 46°C ambient.

Reversible units (CXAM) in heating mode are able to operate from -10°C to 20°C ambient.

Refrigerant Circuit and Capacity Modulation

Each refrigerant circuit has scroll compressors piped in parallel with a passive oil management system. A passive oil management system maintains proper oil levels within compressors and has no moving parts. Each refrigerant circuit includes

- Filter drier : 1 on each liquid line (1 for Cooling only units / 2 for Reversible units)
- Electronic expansion valve.

Capacity modulation is achieved by turning compressors on and off. Units with single circuit have two capacity stages. Units with dual circuit have four capacity stages.

Unit Controls (Trane CH530)

The microprocessor-based control panel is factory-installed and factory-tested. The control system is powered by a pre-wired control power transformer, and will turn on and off compressors to meet the load. Microprocessor-based chilled water reset based on return water is standard.

The Trane CH530 microprocessor automatically acts to prevent unit shutdown due to abnormal operating conditions associated with low evaporator refrigerant temperature and high condensing temperature. If an abnormal operating condition continues and the protective limit is reached, the machine will shut down.

The panel includes machine protection for the following conditions:

- Low evaporator refrigerant temperature and pressure
- High condenser refrigerant pressure
- Critical sensor or detection circuit faults
- High compressor discharge temperature (with low temp evaporator)
- Lost communication between modules
- Electrical distribution fault: phase reversal
- External and local emergency stop
- Loss of evaporator water flow

When a fault is detected, the control system conducts more than 100 diagnostic checks and displays results. The display will identify the fault, indicate date, time, and operating mode at time of occurrence, and provide type of reset required and a help message.

Clear Language Display Panel

Factory-mounted to the control panel door, the operator interface has an LCD touch-screen display for operator input and information output. This interface provides access to the following information: evaporator report, condenser report, compressor report, operator settings, service settings, service tests, and diagnostics. All diagnostics and messages are displayed in "clear language."

Data contained in available reports includes:

- Water and air temperatures
- Refrigerant pressures and temperatures
- Flow switch status
- EXV position
- Compressor starts and run-time

All necessary settings and setpoints are programmed into the microprocessor-based controller via the operator interface. The controller is capable of receiving signals simultaneously from a variety of control sources, in any combination, and priority order of control sources can be programmed. The control source with priority determines active setpoints via the signal it sends to the control panel. Control sources may be:

- Local operator interface (standard)
- Hard-wired 4-20 mA or 2-10 Vdc signal from an external source (interface optional; control source not supplied)
- Time of day scheduling (optional capability available from local operator interface)
- LonTalk LCI-C (interface optional; control source not supplied)
- BACNet (interface optional; control source not supplied)
- ModBus (interface optional; control source not supplied)
- Trane Tracer Summit system (interface optional; control source not supplied)

Quality Assurance

The quality management system applied by Trane has been subject to independent third-party assessment and approval to ISO 9001. The products described in this catalog are designed, manufactured and tested in accordance with the approved system requirements described in the Trane Quality Manual.

Options

Application Options

Ice-Making with Hardwired Interface

Unit controls are factory set to handle ice-making for thermal storage application. This option allows for full load operation of the chiller with leaving evaporator water temperature between -7°C and 18°C.

Low-Temperature Processing

An additional temperature sensor, at the compressor discharge, enables leaving evaporator water temperature below 5.5°C.

Sound Options

Compact

This option includes 920 rpm fans.

Super Quiet Unit

This option includes low speed 700 rpm fans and compressor sound jackets.

Super Quiet with Night Noise Setback

This option will provide two speed fan motors. At night, on a contact closure all the fans run at low speed bringing the overall sound level further down.

Comprehensive Acoustic Package

This option includes low speed 700 rpm fans and acoustical treatment for compressors and refrigerant lines.

Pump Options

Single Standard and High Head Pump Package

Pump package includes: a standard or high head pump, air separator with vent, expansion vessel, drainage valves, and service valves to isolate pump for repair/replacement.

The pump option is single point power integrated into the chiller unit power. The control of the pump is integrated into the chiller controller. The CH530 displays evaporator pump starts and run-times. Freeze protection down to an ambient of -18°C is included as standard. The cold part of the pump package will also be insulated.

Standard head pump is offered for applications that have short water loops or are de-coupled. High head pump is offered for applications where the integrated chiller pump serves the entire loop volume.

Dual Standard and High Head Pump Package

Pump package includes: two standard or high head pumps, air separators with vents, expansion vessels, drainage valves, and service valves to isolate each pump for repair/replacement.

The pump package is single point power integrated into the chiller unit power. The control of the pump is integrated into the chiller controller. The CH530 displays evaporator pump starts and run-times. Freeze protection down to an ambient of -18°C is included as standard. The cold parts of the pump package will also be insulated.

Designed with one redundant pump, it is controlled to operate both pumps through a lead/lag and failure/recovery functionality.

Standard head pump is offered for applications that have short water loops or are de-coupled. High head pump is offered for applications where the integrated chiller pump serves the entire loop volume.

Dual Contactors for Pump (field installed pumps)

Dual pump contacts to control two remote pumps are included in the control panel.

Single Contactor for Pump (field installed pumps)

Single pump contact to control a remote pump is included in the control panel.

Pump Flow Controlled by Mechanical Balancing Valve

A mechanical balancing valve is installed. This option replaced the outlet shut off valve.

Pump Flow Controlled by Variable Speed Drive

A variable speed drive is installed in an additional panel to control the pump. The inverter is adjusted upon start up to balance the system flow and head requirements. The purpose is to save on wasted pump energy caused by a traditional balancing valve.

Options

Buffer Tank (only available with pump package)

The water tank is factory-installed for easy installation at the building site. The tank is engineered for continuous flow and is fully insulated as standard and is designed with freeze protection down to -18°C. The purpose of the tank is to increase the chilled water circuit inertia, which is necessary with short water loops. A high circuit inertia reduces the compressor's cycling to increase the compressor life span and allow for more precise water temperature accuracy. It also saves energy as compared to hot gas bypass.

Electrical Options:

Across-the-Line Starter/Direct on Line

Across-the-line starter is unit mounted with a IP-54 gasketed enclosure.

Across-the-Line Starter/Power Factor Correction

Across-the-line starter is unit mounted with a IP-54 gasketed enclosure. Power factor correction capacitors are factory-installed to correct power factor to 0.95 at all loads.

Solid-State Soft Starter

This option unit mounted starter has a IP-54 gasketed enclosure. To extend starter life contactors bypass current from the silicon control rectifies (SCRs) after startup.

Solid-State Soft Starter/Power Factor Correction

This option unit mounted starter has a IP-54 gasketed enclosure. To extend starter life contactors bypass current from the silicon control rectifies (SCRs) after startup. Power factor correction capacitors are factory-installed to correct power factor to 0.95 at all loads.

Control Options:**LonTalk/Tracer Summit Interface**

LonTalk (LCI-C) or Tracer Summit communications capabilities are available with communication link via single twisted-pair wiring to factory-installed and tested communication board. This option will support the functionality required to obtain Lon Mark certification.

LonTalk LCI-C Interface with Modbus Interface

Allows user to easily interface with Modbus through LonTalk via a single twisted-pair wiring to factory-installed and tested communication board.

Time of Day Scheduling

Time of day scheduling capabilities are available for scheduling single chiller applications through Trane CH530 panel (without the need for building automation system - BAS). This feature allows the user to set up to ten events in a seven day time period.

External Chilled Water and Demand Limit Setpoint

Controls, sensors, and safeties allow reset of chilled water temperature, based on temperature signal, during periods of low outdoor air temperature (chilled water reset based on return chilled water temperature is standard). The demand limit setpoint is communicated to a factory-installed and tested communication board through a 2-10 Vdc or 4-20 mA signal.

Percent Capacity

Output the number of compressors that are operating as an analog 2-10 Vdc or 4-20 mA signal.

Programmable Relays

Predefined, factory-installed, programmable relays allow the operation to select four relay outputs. Available outputs are: Alarm-Latching, Alarm-Auto Reset, General Alarm, Warning, Chiller Limit Mode, Compressor Running, and Tracer Control.

Other Options**Access Guards**

A coated wire mesh that covers the coil along the side of the unit.

Access Guards and Half Louvers

A coated wire mesh covers the access area under the condenser coils and half louvers cover the condenser coil.

Architectural Louvered Panels

Louvered panels cover the complete condensing coil and service area beneath the condenser.

Half Louvers

Louvered panels cover the condenser coil only. Available on the W coil units only.

Non-Lanced Aluminum Fins

Aluminum fins without slits help to prevent sand clogging the slit portion of a standard fin.

Non-Lanced Aluminum Fins with Pre-Coat Black Epoxy

This option uses pre-coated black epoxy non-slit aluminum fin stock for corrosion protection.

Non-Lanced Aluminum Fins with Pre-Coat Blue Fin

This option uses pre-coated non-slit aluminum fin stock to limit coil freezing and then defrost cycle.

Neoprene Pads

Neoprene isolator pads specially dimensioned to reduce vibration transmission to the supporting structure when the unit is installed. Pads ship in the control panel.

Isolators

Molded elastomeric isolators sized to reduce vibration transmission to the supporting structure when the unit is installed. Isolators ship with the chiller.

Flange Adapter

Kit to convert both water connections from grooved pipe to flanged connections. This includes: grooved couplings and grooved to flange adapters.

Hydraulic Data

Figure 16. Pressure drops (through the evaporator - S configuration)

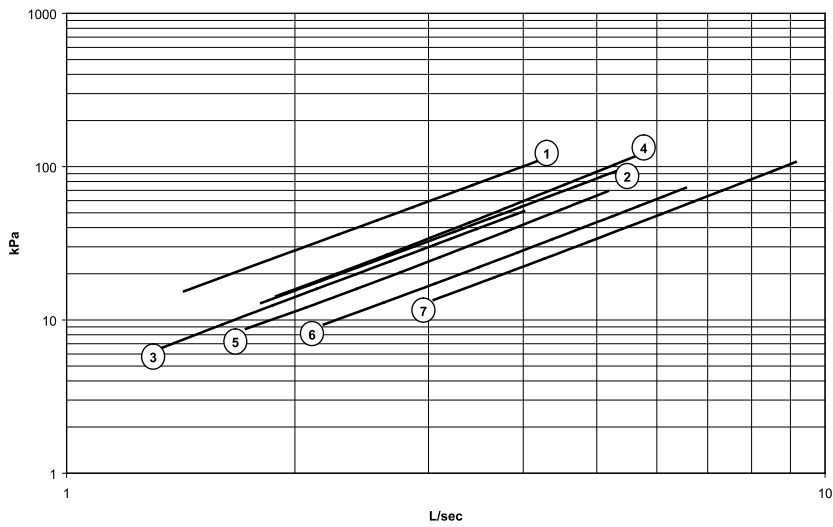

- 1 20 SE - 23SE - 26 SE SQ - 26 SE CP
- 2 30 SE SQ - 30 SE CP
- 3 20 HE - 23 HE SQ - 23 HE CP
- 4 23 HE CAP - 26 HE CAP - 30 HE SQ
- 30 HE CP - 30 SE CAP
- 5 26 HE SQ - 26 HE CP - 30 HE CAP
- 35 SE
- 6 35 HE - 39 SE
- 7 45 SE - 50 SE

Figure 17. Pressure drops (through the evaporator - V and W configurations)

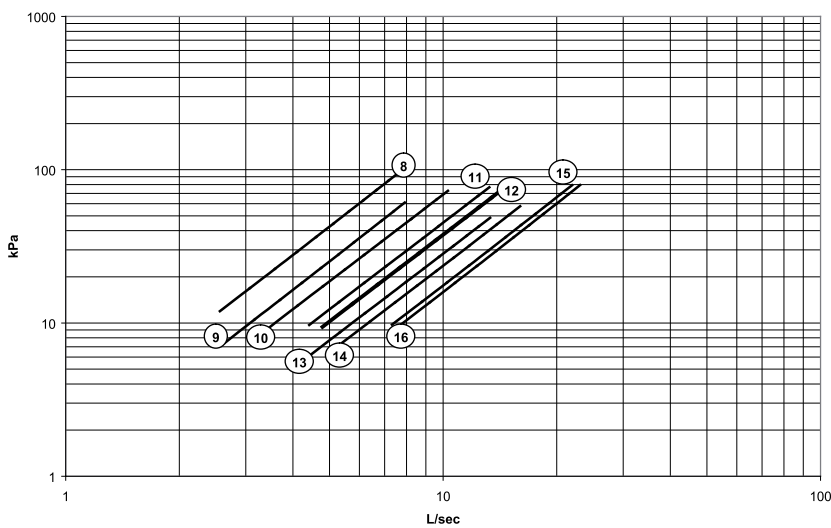

- 8 40 SE
- 9 40 HE - 46 HE SQ - 46 HE CP
- 46 SE - 52 SE
- 10 52 HE - 46 HE CAP - 60 HE - 60 SE
- 11 70 SE
- 12 80 SE - 90 SE CAP
- 13 70 HE - 90 SE SQ - 90 SE CP
- 14 80 HE SQ - 80 HE CP - 100 SE
- 110 SE - 120 SE CAP
- 15 80 HE CAP - 90 HE - 110 HE SQ
- 110 HE CP - 120 SE SQ
- 120 SE CP - 140 SE
- 16 100 HE - 110 HE CAP - 120 HE
- 140 HE - 150 HE - 150 SE
- 160 HE - 160 SE - 170 SE

Hydraulic Data

Figure 18. Pressure drops through the strainer

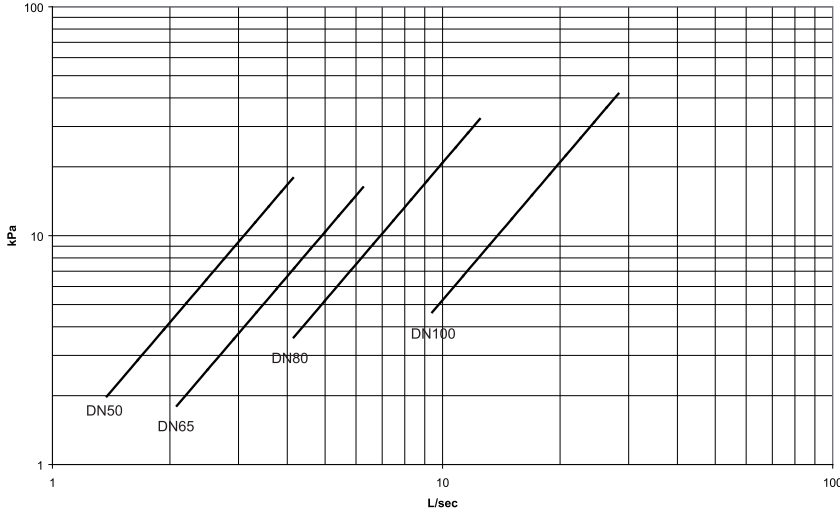
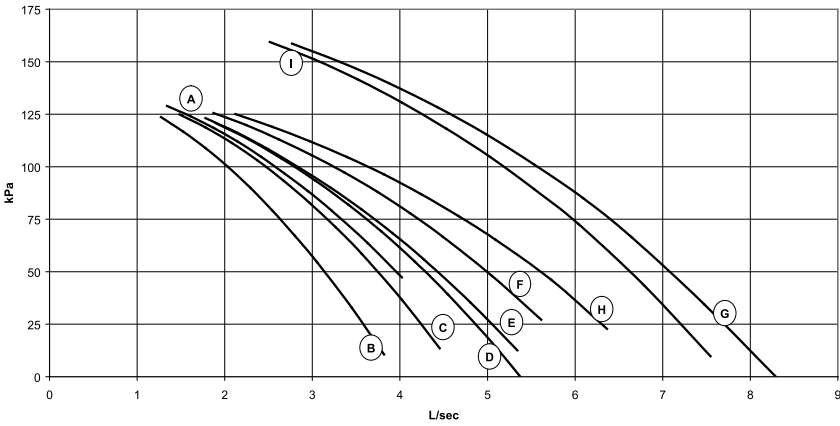

Figure 19. Available pressure - S coil configuration - Standard head



- A 20 HE - 23 HE SQ - 23 HE CP
- 26 SE CAP
- B 20 SE - 23 SE - 26 SE SQ - 26 SE CP
- C 23 HE CAP - 26 HE CAP
- D 26 HE SQ - 26 HE CP - 30 HE SQ
- 30 HE CP - 30 SE CAP
- E 30 SE SQ - 30 SE CP
- F 30 HE CAP - 35 SE
- G 45 SE - 50 SE
- H 35 HE
- I 39 SE

Figure 20. Available pressure - S coil configuration - High head

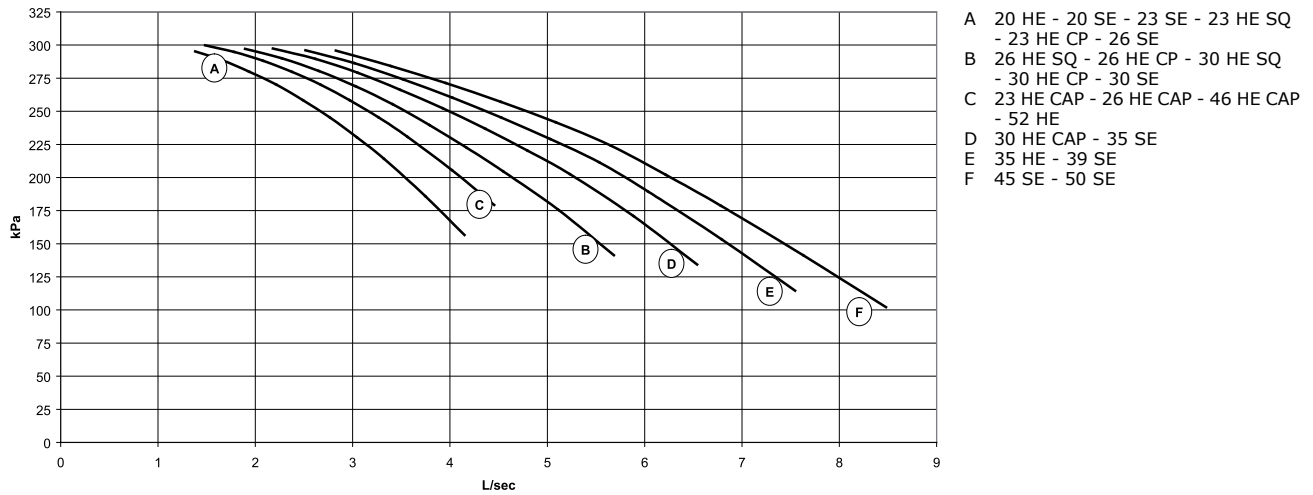
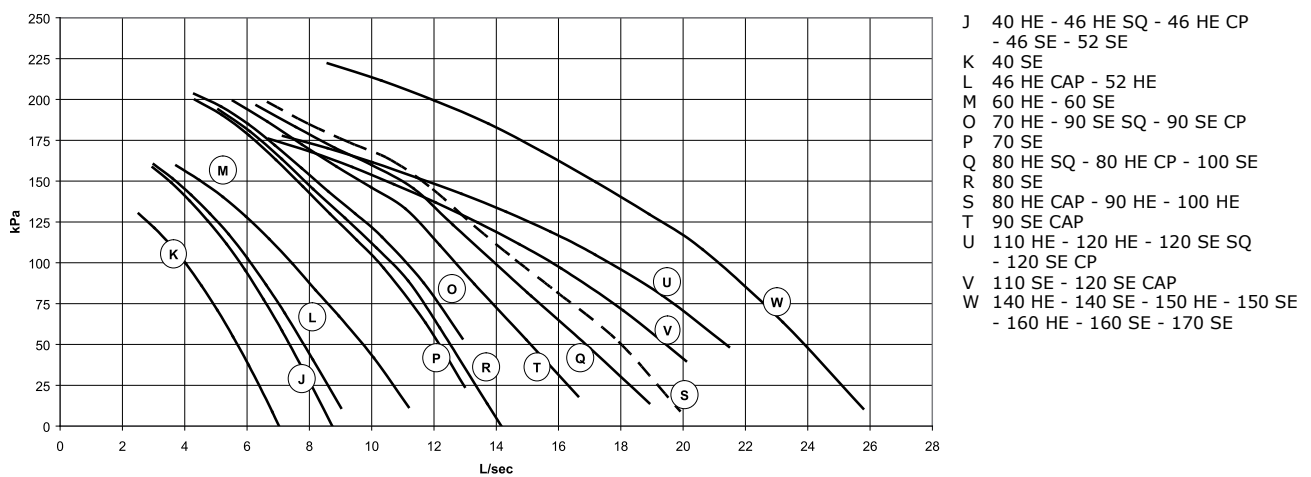
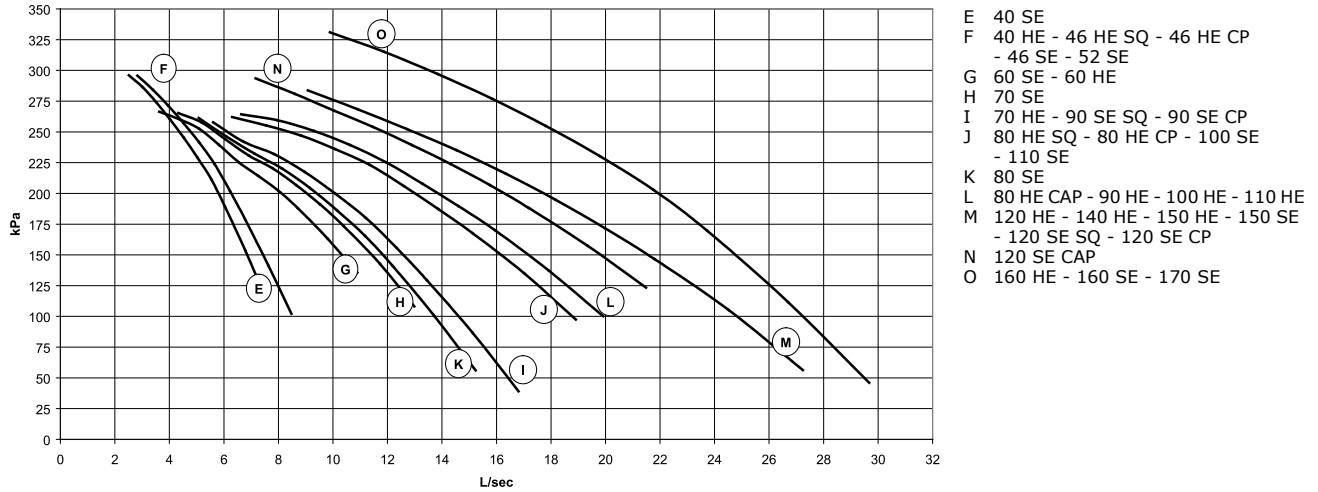

Figure 21. Available pressure - V and W coil configurations - Standard head



Hydraulic Data

Figure 22. Available pressure - V and W coil configurations - High head



- E 40 SE
- F 40 HE - 46 HE SQ - 46 HE CP
- 46 SE - 52 SE
- G 60 SE - 60 HE
- H 70 SE
- I 70 HE - 90 SE SQ - 90 SE CP
- J 80 HE SQ - 80 HE CP - 100 SE
- 110 SE
- K 80 SE
- L 80 HE CAP - 90 HE - 100 HE - 110 HE
- M 120 HE - 140 HE - 150 HE - 150 SE
- 120 SE SQ - 120 SE CP
- N 120 SE CAP
- O 160 HE - 160 SE - 170 SE

Operating Map

Figure 23. Operating map - cooling mode

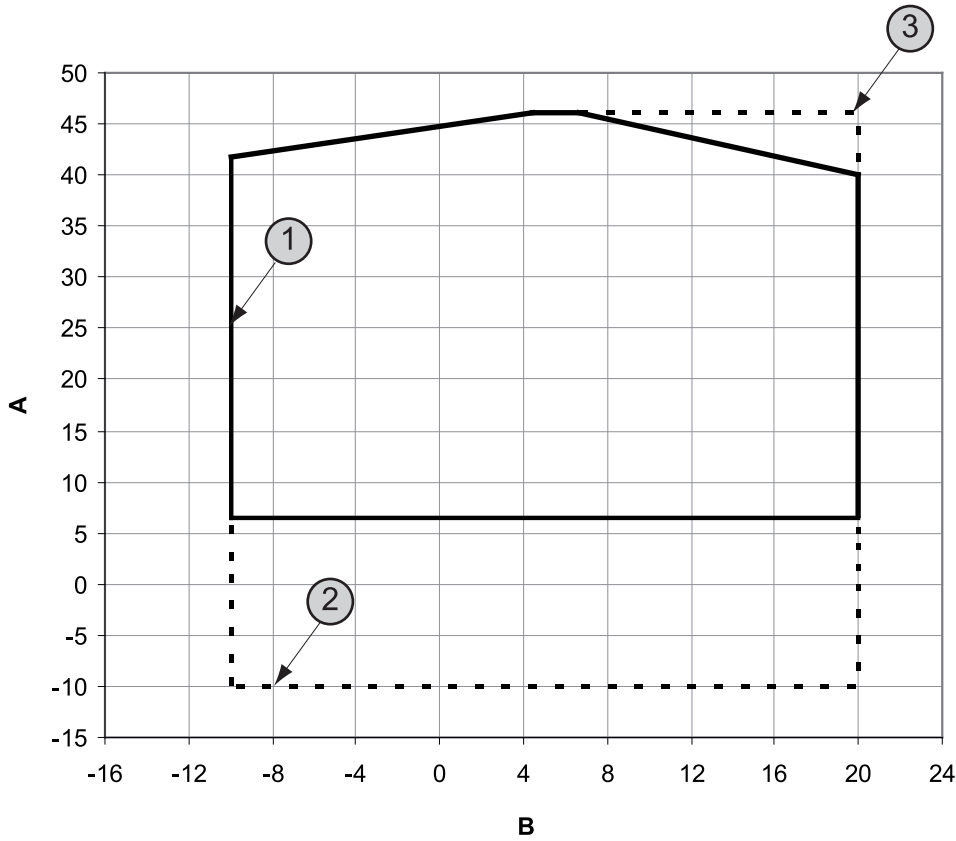

- A = Entering air temperature (°C)
- B = Leaving water temperature (°C)
- 1 = Standard operating map
- 2 = Low ambient operating map (requires inverter)
- 3 = Part load operating map

Operating Map

Figure 24. Operating map - heating mode

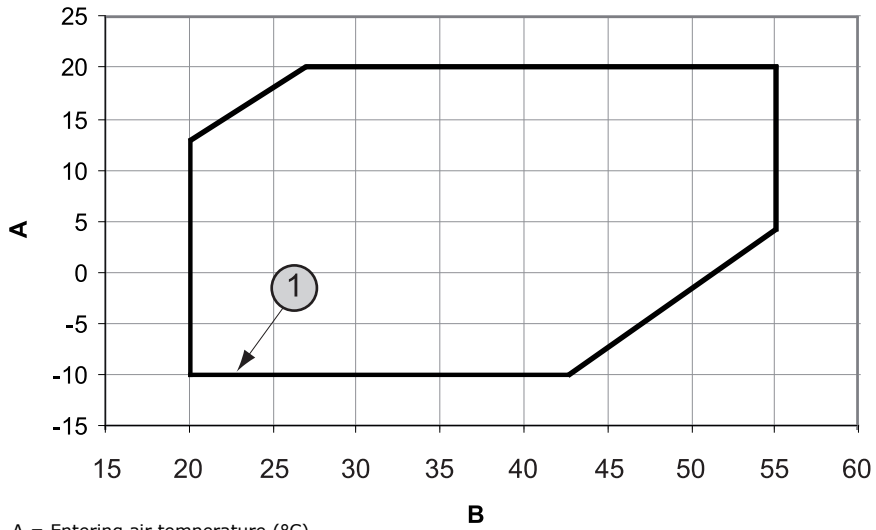

A = Entering air temperature (°C)
B = Leaving water temperature (°C)
1 = Standard operating map

Unit Schematics

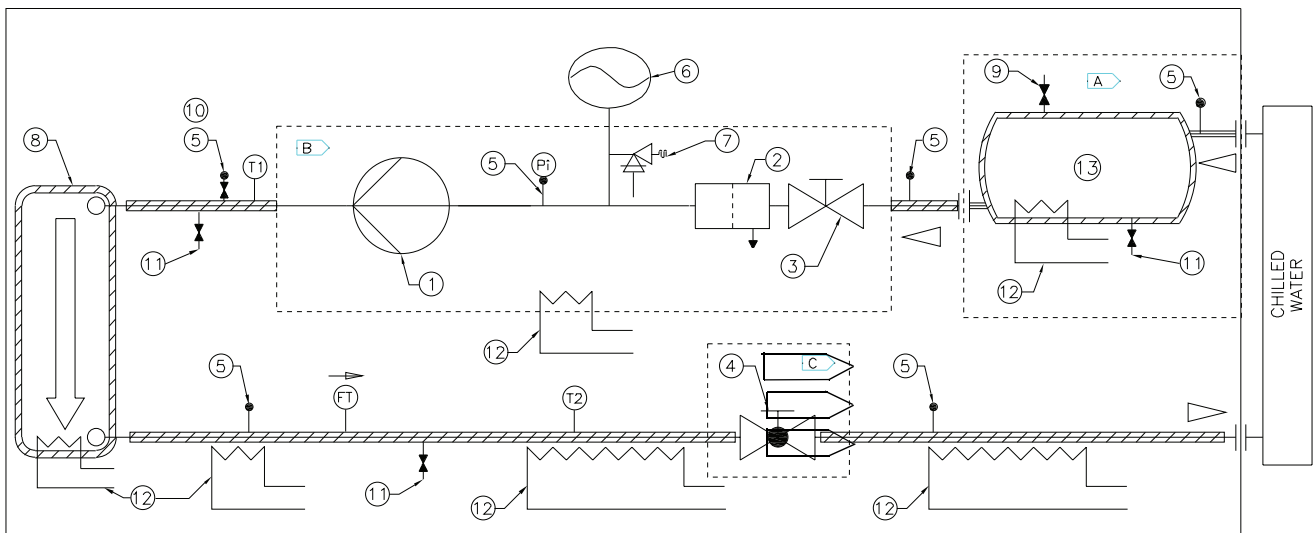
Figure 25. Hydraulic module water chart

- | | | | |
|----|-------------------------------|----|--------------------------|
| 1 | Single or Dual Pump | 8 | Exchanger |
| 2 | Water Strainer | 9 | Automatic Air Bleed |
| 3 | Shut Off Valve | 10 | Manual Air Bleed |
| 4 | Shut off or Balancing Valve | 11 | Drain Valve |
| 5 | Valve for Pressure Point | 12 | Antifreeze Protection |
| 6 | Expansion Tank | 13 | Buffer Tank |
| 7 | Relief valve | | |
| Pi | Gauge | A | Optional Buffer Tank |
| FT | Water Flow Switch | B | Pump box |
| T1 | Evap Water Inlet Temp Sensor | C | Optional balancing valve |
| T2 | Evap Water Outlet Temp Sensor | | |

Water Line
 Insulated Water Line

Unit Schematics

Figure 26. CXAM Refrigerant Circuit - W coil configuration without dedicated subcooler

	REFRIGERANT LINE
	CHILLED / HEATED WATER LINE
	INSULATION

- 1 ONLY FOR CXAM «W» 140-150-160-170
- 2 PARTIAL HEAT RECOVERY OPTION

- C1 = circuit 1
- C2 = circuit 2
- CP = Control panel
- DL = Discharge line
- SL = Suction line
- LL = Liquid line
- 1 = Scroll compressor
- 2 = Evaporator
- 3 = Condenser
- 4 = Partial heat recovery exchanger
- 5 = Filter drier (cooling mode)
- 6 = Electronic expansion valve (cooling mode)
- 7 = Service valve
- 8 = Schraeder valve
- 9 = Sight glass
- 10 = Receiver
- 11 = 4 way reversing valve
- 12 = Filter drier (heating mode)
- 13 = Electronic expansion valve (heating mode)
- 14 = Receiver fill valve
- 15 = Receiver check valve
- PT = Pressure transducer
- PZH = High pressure switch
- TT = Temperature sensor
- TCE = Electronic expansion valve
- FSL = Evaporator water flow switch

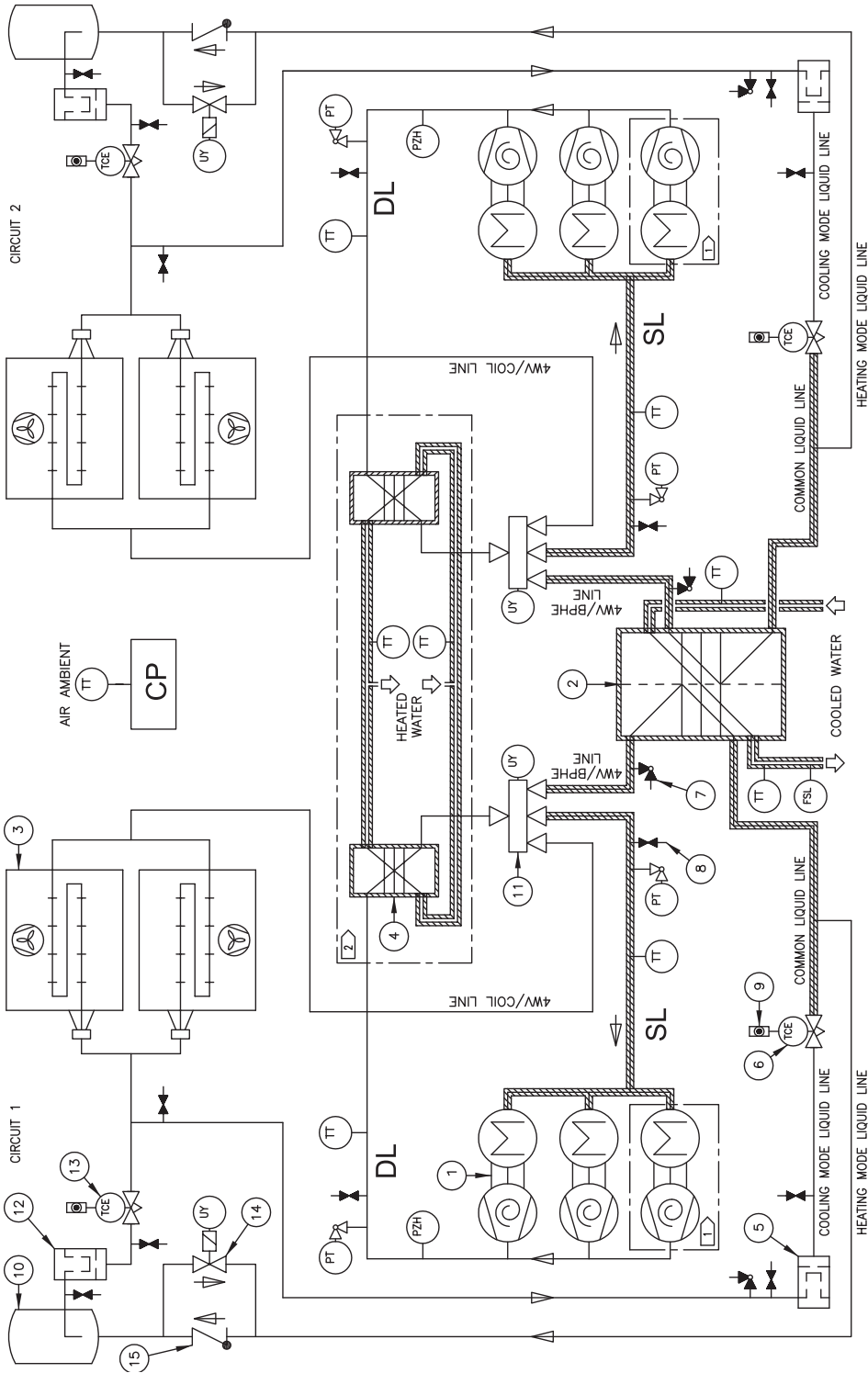

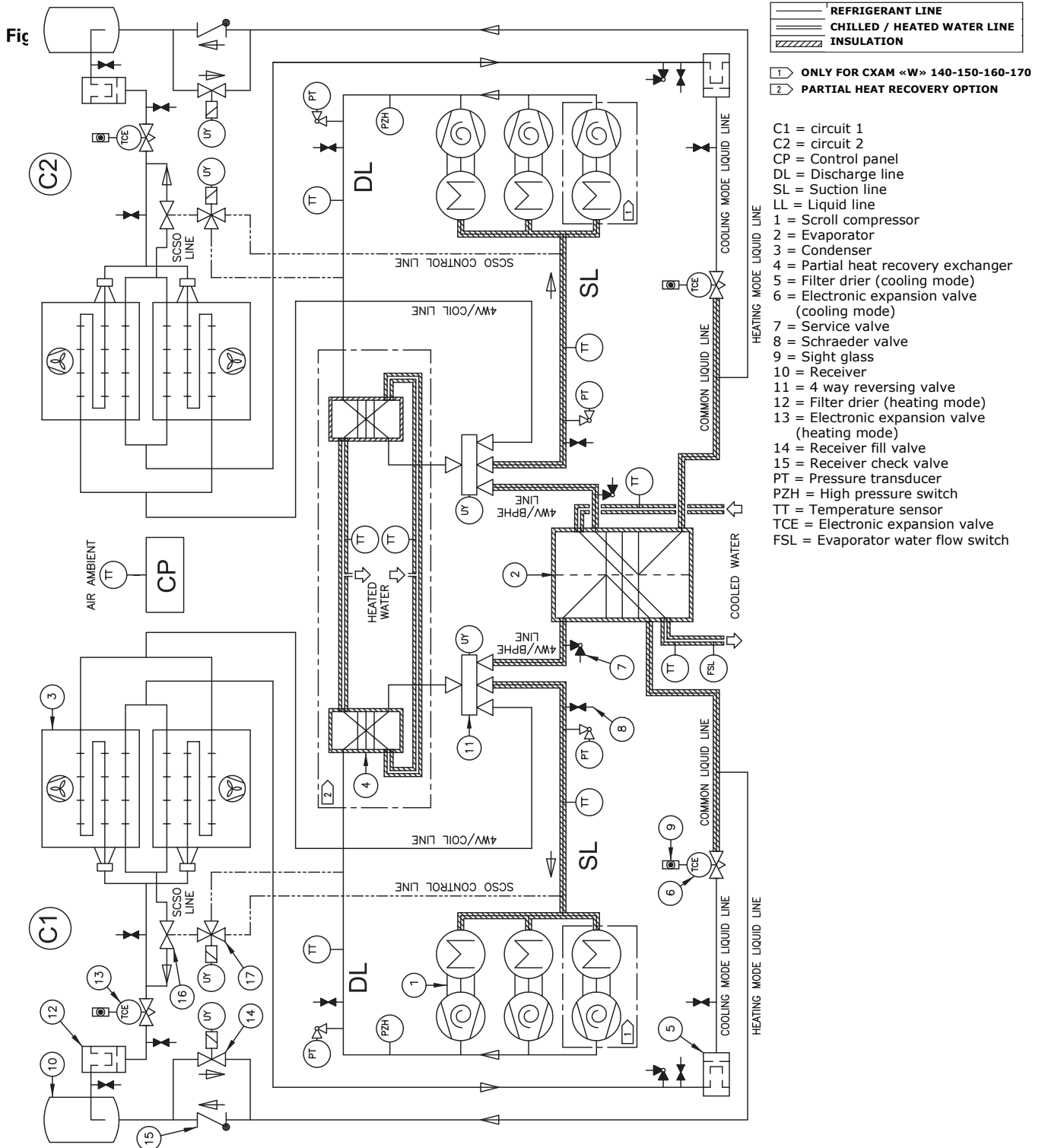

Unit Schematics

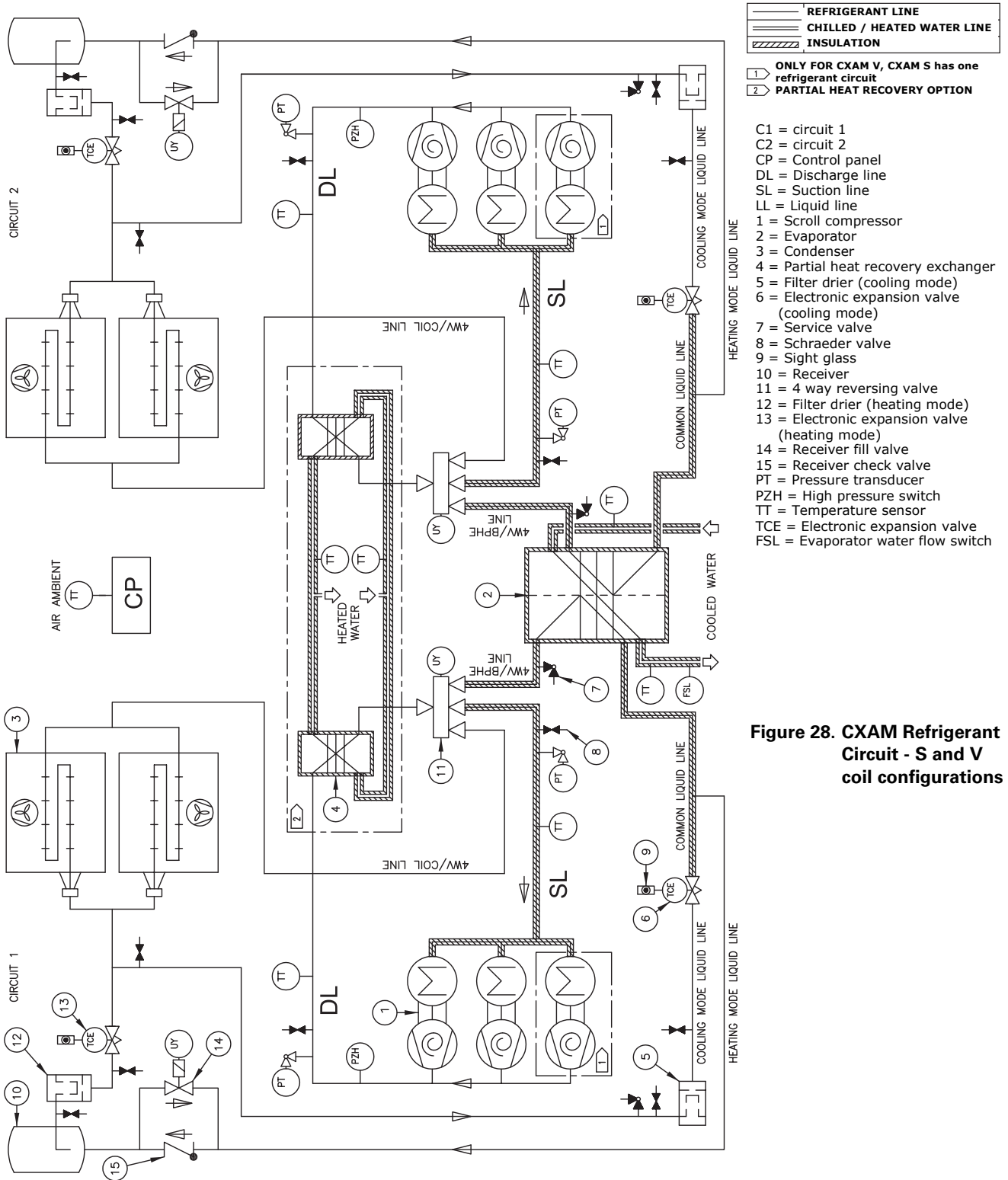

Figure 28. CXAM Refrigerant Circuit - S and V coil configurations



Trane optimizes the performance of homes and buildings around the world. A business of Ingersoll Rand, the leader in creating and sustaining safe, comfortable and energy efficient environments, Trane offers a broad portfolio of advanced controls and HVAC systems, comprehensive building services, and parts. For more information, visit www.Trane.com.

Trane has a policy of continuous product and product data improvement and reserves the right to change design and specifications without notice.